



Repair Kit for EDP16TE, EDP16HAZ, ADP16 and ADP20 Free-Air® Pumps

Kit (15922) Contains

Qty.	Part No.	Description
4	Carbon vanes
1 23611	Inlet filter
1 S17101	Outlet filter cartridge

▲ WARNING ▲

ELECTRIC-DRIVEN PUMPS: DISCONNECT POWER OR UNPLUG MOTOR CORD BEFORE DISASSEMBLING EDP16TE OR EDP16HAZ PUMPS. FAILURE TO DO SO MAY RESULT IN ELECTRIC SHOCK OR PERSONAL INJURY.

AIR-DRIVEN PUMPS: DISCONNECT DRIVE AIR SUPPLY ON ADP16 OR ADP20 PUMPS BEFORE DISASSEMBLING. FAILURE TO DO SO MAY RESULT IN PERSONAL INJURY.

Distributed by:
Safety Emporium
PO Box 1003
Blackwood, NJ 08012
Ph: (866) 326-5412 toll-free
Fax: (856) 553-6154
esupport@safetyemporium.com
www.safetyemporium.com

Carbon Vane Replacement

DISASSEMBLY:

1. Remove fan guard by removing four retaining screws. See Figure 1.
2. Remove fan by first removing retaining ring from inside center of fan where fan fits over the shaft. This may be done with a screw driver or with medium spring 90° snap ring pliers.

Pry fan off shaft using two screwdrivers, one on each side.

3. Remove bolts from end plate. Using a puller, remove end plate including bearing assembly from shaft. Puller needs a minimum of 2-inch reach and 2 5/8-inch spread.

NOTE: Since puller jack screw bears on the center of the rotor shaft of the pump, the rotor will remain in place undisturbed. Do not remove rotor or disrupt internal clearance.

4. Remove used vanes.
5. Brush or blow to clean rotor assembly.
6. Inspect inside surface of end plate for any deep scratches.
7. Inspect rotor for rust and clean if necessary.
8. Install new carbon vanes. Be sure that beveled edge of vane faces the outside of the rotor. (The flat edge should face the inside of the rotor. See Figure 2. Make sure that vanes slide freely in the rotor slot).

NOTE: The carbon vanes are fragile. Handle with care.

9. Rotate rotor by hand. Rotor should turn easily with no drag. If rotor drags, the vanes may be installed incorrectly. If vanes are installed correctly and rotor continues to drag, the pump may be damaged and may require factory repair. Contact our Customer Service Team at 800-827-0423 for assistance.

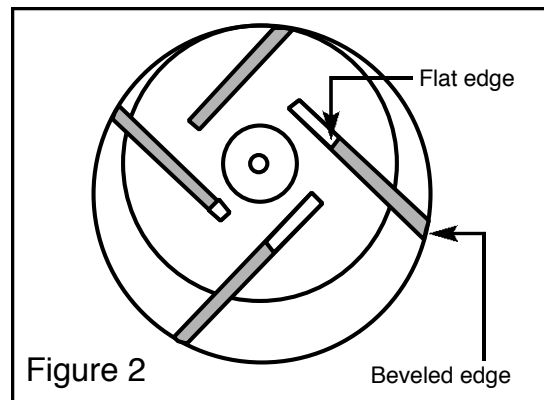
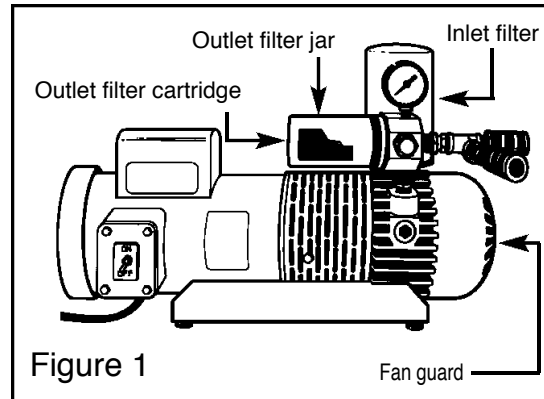

- | | |
|---|-----------------------------|
| 1 | Body |
| 2 | Rotor Assembly |
| 3 | Vane |
| 4 | Body Gasket |
| 5 | Foot Bracket |
| 6 | Deflector |
| 7 | Ball Bearing (Drive & Dead) |
| 8 | End Cap, Drive |

Carbon Vane Replacement

REASSEMBLY (See Figure 4)

10. Remove wheel puller from end plate to remove bearings.
11. Remove bearing snap ring using snap ring pliers. Ref. No. 14.
12. Remove all retaining washers (12, 13, 14) from end plate housing (11).
13. Remove bearing (7) from end plate (11) by punching it out.
14. Replace end plate (11) and bolts and hand tighten.
15. Torque bolts to 20lb pressure using 1/2-inch socket. Tighten bolts in order as shown in Figure 3.
16. Check shaft for ease of rotation.
17. Replace deflector (6) and bearing (7) assembly. A hammer may be used to tap the bearing onto the shaft and seat it correctly within the housing. Bearing must be beyond the snap ring groove in the housing.
18. Replace Belleville springs (12) and washer (13).
19. Replace large snap ring (14) with 90° snap ring pliers.
20. Replace small snap ring on fan housing.
21. Replace fan (15) on shaft.
22. Rotate fan to make sure shaft moves freely.
23. Replace fan cover (16) and 4 screws.

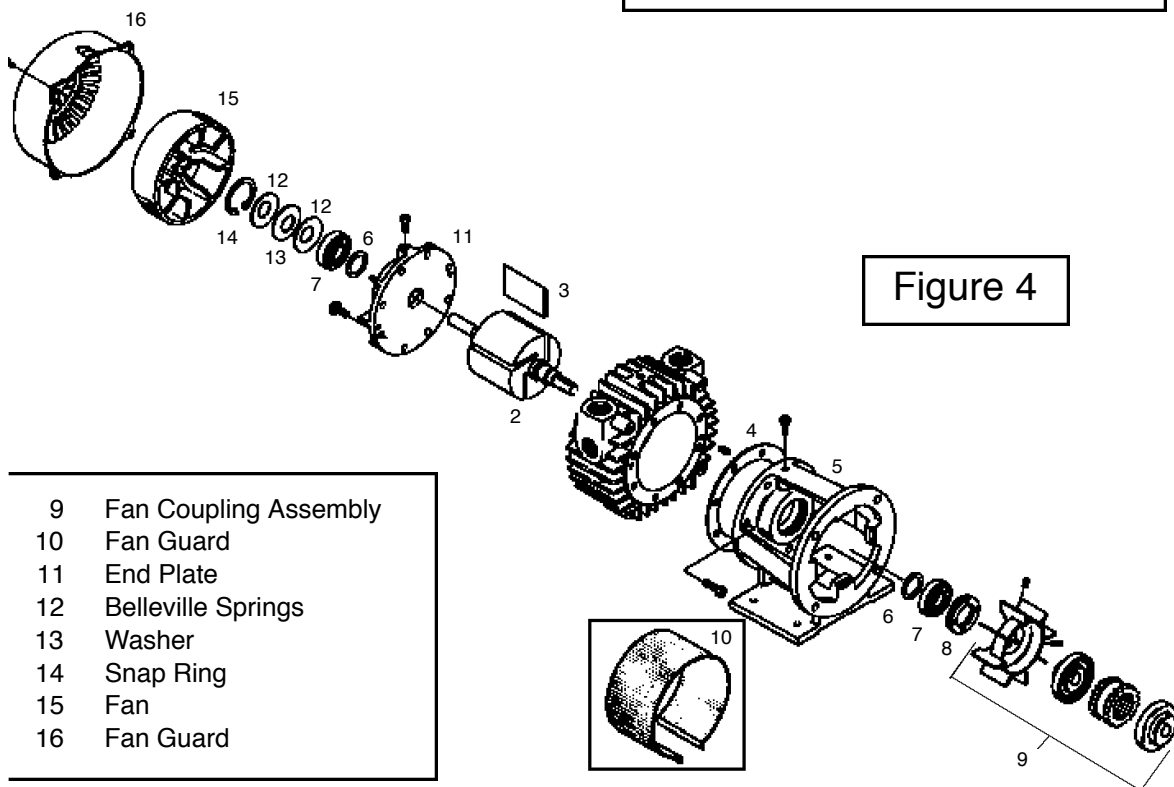
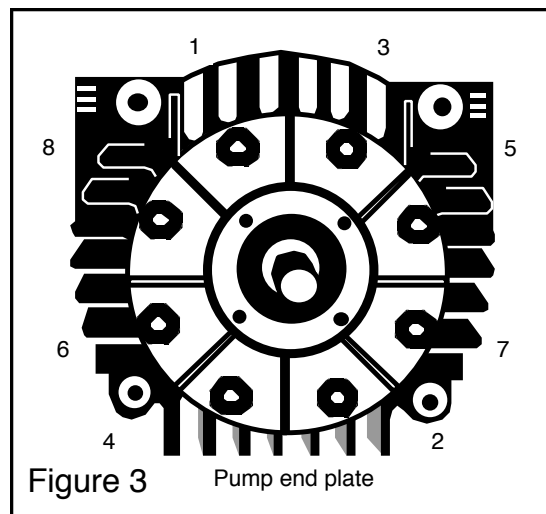

Outlet Filter Replacement

1. Unscrew and remove outlet filter jar by turning counter-clockwise.
2. Remove wing nut and metal retainer holding filter cartridge in place.
3. Install new filter (Cat. No. S17101) cartridge and reassemble. Make sure the jar makes a tight seal.

Inlet Filter Replacement

1. Unscrew and remove inlet filter by turning counter-clockwise.
2. Replace with new inlet air filter (Cat. No. 23611) and hand tighten.

RECOMMENDED: REPLACE THE INLET FILTER EVERY 500 RUNNING HOURS, OR MORE OFTEN IF REQUIRED. REPLACE THE OUTLET FILTER CARTRIDGE EVERY 200 RUNNING HOURS OR MORE OFTEN IF REQUIRED.

Distributed by:
Safety Emporium
PO Box 1003
Blackwood, NJ 08012
Ph: (866) 326-5412 toll-free
Fax: (856) 553-6154
esupport@safetyemporium.com
www.safetyemporium.com

