



### □ **AP280-230** Electric Alarm Unit for Recessed Laboratory Units

**APPLICATION:** Alarm units serve two important functions when installed in conjunction with emergency eyewash and shower equipment. First, alarms serve to alert facility personnel that an accident has occurred and that assistance to the user may be required. Second, alarms deter unintended or malicious operation of the emergency equipment. For this reason, they are advisable in schools and other areas where the possibility of vandalism is present. Alarms are activated by a flow switch that senses the movement of water in the supply line when the safety unit is activated. Once activated, the bright light flashes and the horn sounds loudly.

**INSTALLATION:** Unit is designed for use with recessed laboratory units. Combination light and alarm horn is recess mounted in wall. Flow switch and electrical wiring are located behind wall. 120 volt, 0.11 amp electrical supply is required.

**VISUAL SIGNAL:** Amber strobe light with shatter-resistant lens.

**AUDIBLE SIGNAL:** Horn delivers distinctive, urgent signal at 90 db.

**FLOW SWITCH:** 1" IPS single pole, double throw waterproof flow switch for installation in water supply line to emergency unit. Switch senses flow of water when either the eyewash or shower is activated. Flow switch must be installed with tee fitting in horizontal position, flow switch body in vertical position and at least 6" from closest fitting. Direction of flow is marked on switch body.

**MOUNTING:** Furnished with hardware for recess mounting components in finished wall. Electrical connections by others.

**QUALITY ASSURANCE:** All components are factory tested prior to shipment.

### Additional Models

□ **AP280-235** Same as above except with double pole, double throw flow switch for connection to monitoring system. When emergency unit is actuated, light and horn activate and electrical signal is sent to remote monitoring location.



Distributed by:  
Safety Emporium  
PO Box 1003  
Blackwood, NJ 08012  
Ph: (866) 326-5412 toll-free  
Fax: (856) 553-6154  
[esupport@safetyemporium.com](mailto:esupport@safetyemporium.com)  
[www.safetyemporium.com](http://www.safetyemporium.com)



### AP280-230 Electric Alarm Unit for Recessed Laboratory Units

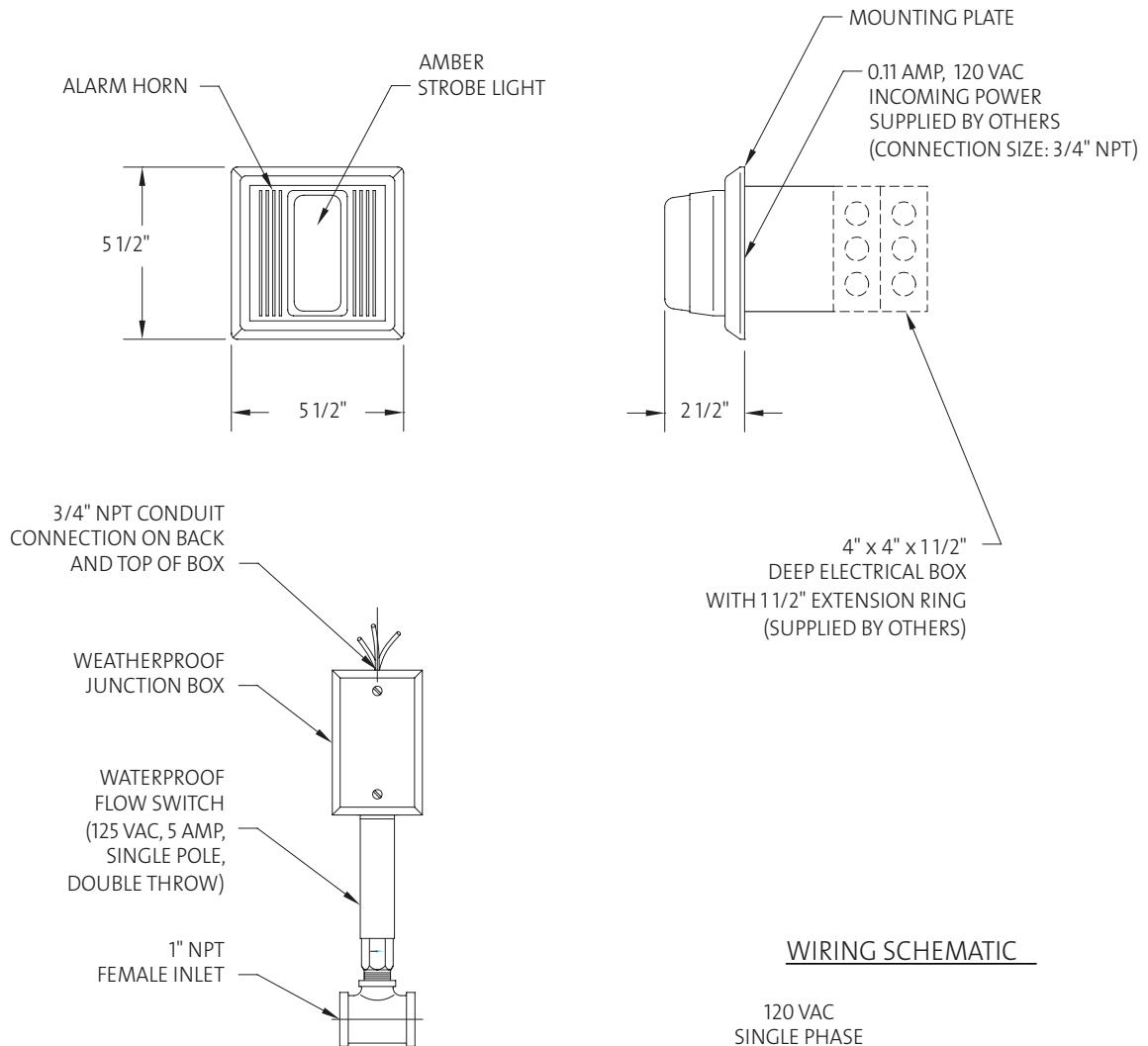

#### NOTES:

1. FLOW SWITCH IS DESIGNED TO ACTIVATE AT 3.0 GPM AND DEACTIVATE AT 1.75 GPM.
2. FLOW SWITCH MUST BE INSTALLED VERTICALLY IN A HORIZONTAL PIPE RUN, UPSTREAM OF UNIT AND AT LEAST 6" FROM FITTING.
3. SOUND OUTPUT ON HORN IS 90 dB AT 10 FEET.
4. ALL WIRING TO BE PROVIDED BY OTHERS.

#### WIRING SCHEMATIC

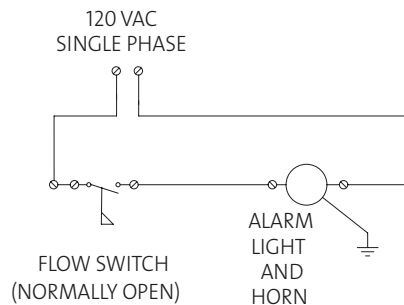

THIS SPACE FOR ARCHITECT/ENGINEER APPROVAL

Due to continuing product improvement, the information contained in this document is subject to change without notice. All dimensions are  $\pm 1/4"$  (6mm). rev. 0312