



- G5014** Eyewash/Drench Hose Unit, Wall Mounted, 12' Coiled Hose, Ball Valve with Flag Handle
- G5014BP** Eyewash/Drench Hose Unit, Wall Mounted, 12' Coiled Hose, Ball Valve with Flag Handle with Backflow Preventer



Distributed by:
Safety Emporium
PO Box 1003
Blackwood, NJ 08012
Ph: (866) 326-5412 toll-free
Fax: (856) 553-6154
esupport@safetyemporium.com
www.safetyemporium.com

Application: Dual purpose eyewash/drench hose with ball valve and flag handle for wall mounting. Unit meets the provisions of ANSI Z358.1-2014 as both an eyewash and a drench hose. Unit may be left in the mounting bracket for use as a fixed eyewash, leaving user's hands free. Alternatively, unit may be removed for use as a drench hose to rinse any part of user's eyes, face or body. 12' nylon retractable hose coils to eliminate trip hazard.

Spray Head Assembly: Two GS-Plus™ spray heads mounted side-by-side. Each head has a "flip top" dust cover, internal flow control and filter to remove impurities from the water flow.

Valve: 1/2" IPS chrome plated brass stay-open ball valve. Valve is US-made with chrome plated brass ball and PTFE seals.

Hose: 12' reinforced nylon retractable coiled hose. 180 PSI maximum working pressure.

Mounting: Bracket with spring clips to hold unit on wall. Clips assure that spray heads face forward at all times.

Backflow Preventer: In-line dual check backflow preventer installed on inlet of hose (G5014BP only). ASSE 1024 Listed.
Note: Check with code authority for compliance with local plumbing code.

Supply: 3/8" NPT female inlet.

Sign: ANSI-compliant identification sign.

Quality Assurance: Unit is completely assembled and water tested prior to shipment.

Available Options

- VB** In-line vacuum breaker for installation between valve and spray head.
- G3600LF** Thermostatic mixing valve precisely blends hot and cold water to deliver warm (tepid) water as required by ANSI Z358.1-2014. Refer to "Tempering Valves" section for complete technical and product selection information.



G5014 Eyewash/Drench Hose Unit, Wall Mounted, 12' Coiled Hose, Ball Valve with Flag Handle

G5014BP Eyewash/Drench Hose Unit, Wall Mounted, 12' Coiled Hose, Ball Valve with Flag Handle with Backflow Preventer

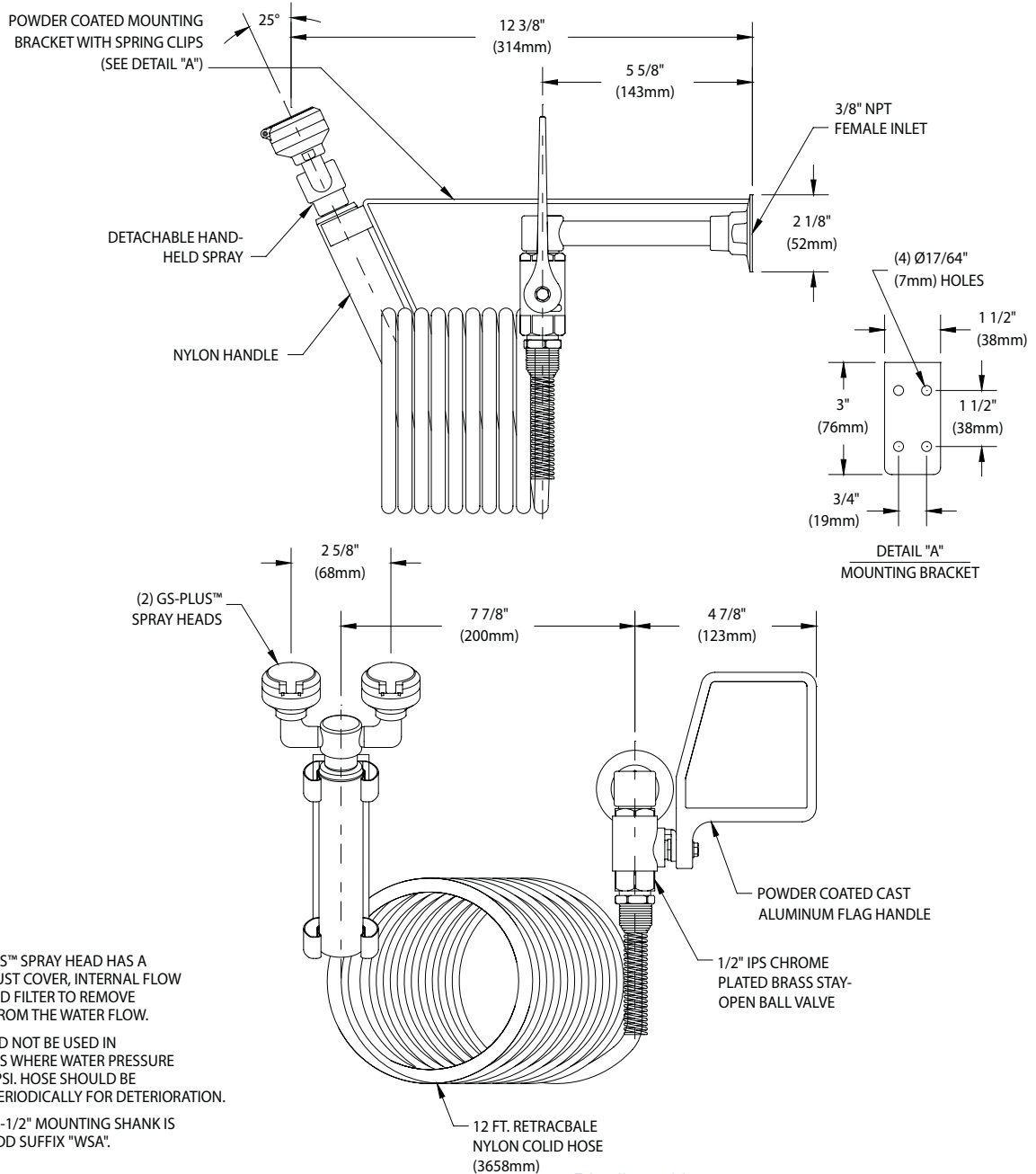

NOTES:

1. EACH GS-PLUS™ SPRAY HEAD HAS A "FLIP-TOP" DUST COVER, INTERNAL FLOW CONTROL AND FILTER TO REMOVE IMPURITIES FROM THE WATER FLOW.
2. HOSE SHOULD NOT BE USED IN APPLICATIONS WHERE WATER PRESSURE EXCEEDS 90 PSI. HOSE SHOULD BE INSPECTED PERIODICALLY FOR DETERIORATION.
3. IF 3/8" IPS X 2-1/2" MOUNTING SHANK IS REQUIRED, ADD SUFFIX "WSA".

THIS SPACE FOR ARCHITECT/ENGINEER APPROVAL

Due to continuing product improvement, the information contained in this document is subject to change without notice. All dimensions are ± 1/4" (6mm). rev. 022019

Distributed by:
Safety Emporium
 PO Box 1003
 Blackwood, NJ 08012
 Ph: (866) 326-5412 toll-free
 Fax: (856) 553-6154
esupport@safetyemporium.com
www.safetyemporium.com

Sign Included

