

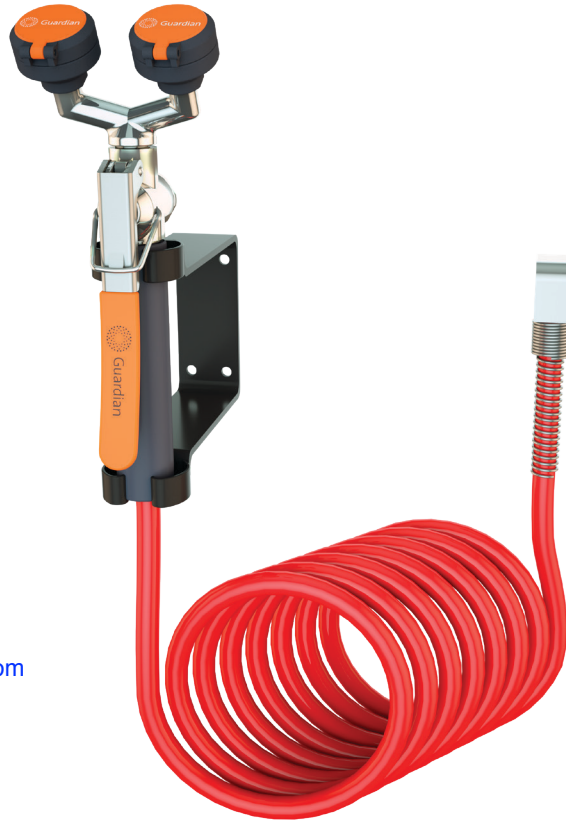

- G5046** Eyewash/Drench Hose Unit, Wall Mounted, 12' Coiled Hose
- G5046BP** Eyewash/Drench Hose Unit, Wall Mounted, 12' Coiled Hose, with Backflow Preventer



Distributed by:
Safety Emporium
PO Box 1003
Blackwood, NJ 08012
Ph: (866) 326-5412 toll-free
Fax: (856) 553-6154
esupport@safetyemporium.com
www.safetyemporium.com

Application: Dual purpose eyewash/drench hose with 12' coiled hose for wall mounting. Unit meets the provisions of ANSI Z358.1-2014 as both an eyewash and a drench hose. Unit may be left in the mounting bracket for use as a fixed eyewash, leaving user's hands free. Alternatively, unit may be removed for use as a drench hose to rinse any part of user's eyes, face or body. 12' nylon retractable hose coils to eliminate trip hazard.

Spray Head Assembly: Two GS-Plus™ spray heads mounted side-by-side. Each head has a "flip top" dust cover, internal flow control and filter to remove impurities from the water flow.

Valve: Forged brass squeeze valve activated by stainless steel lever handle. Valve has replaceable stainless steel seat for exceptional durability. Locking clip engages when handle is depressed, providing "hands free" operation. Valve stays open until locking clip is released.

Hose: 12' reinforced nylon retractable coiled hose. 180 PSI maximum rated working pressure.

Mounting: Bracket with spring clips to hold unit on wall. Clips position spray heads and handle to face forward at all times.

Backflow Preventer: In-line dual check backflow preventer installed on inlet of hose (G5046BP only). ASSE 1024 Listed.
Note: Check with code authority for compliance with local plumbing code.

Supply: 3/8" NPT female inlet.

Sign: ANSI-compliant identification sign.

Quality Assurance: Unit is completely assembled and water tested prior to shipment.

Available Options

- VB** In-line vacuum breaker for installation between valve and spray head.
- G3600LF** Thermostatic mixing valve precisely blends hot and cold water to deliver warm (tepid) water as required by ANSI Z358.1-2014. Refer to "Tempering Valves" section for complete technical and product selection information.



- **G5046** Eyewash/Drench Hose Unit, Wall Mounted, 12' Coiled Hose
- **G5046BP** Eyewash/Drench Hose Unit, Wall Mounted, 12' Coiled Hose, with Backflow Preventer

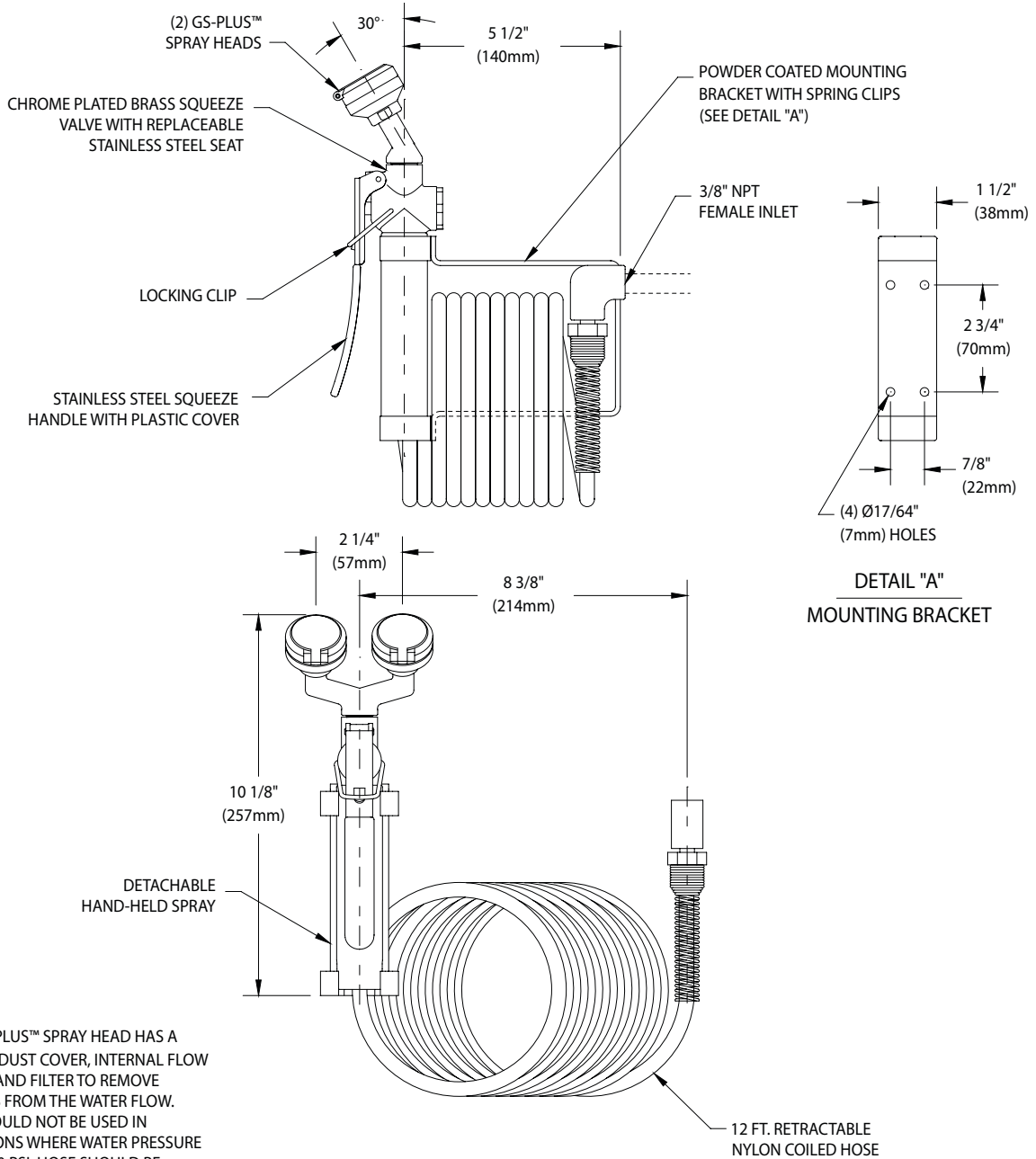

- NOTES:
1. EACH GS-PLUS™ SPRAY HEAD HAS A "FLIP-TOP" DUST COVER, INTERNAL FLOW CONTROL AND FILTER TO REMOVE IMPURITIES FROM THE WATER FLOW.
 2. HOSE SHOULD NOT BE USED IN APPLICATIONS WHERE WATER PRESSURE EXCEEDS 90 PSI. HOSE SHOULD BE INSPECTED PERIODICALLY FOR DETERIORATION.

THIS SPACE FOR ARCHITECT/ENGINEER APPROVAL

Distributed by:
Safety Emporium
 PO Box 1003
 Blackwood, NJ 08012
 Ph: (866) 326-5412 toll-free
 Fax: (856) 553-6154
 esupport@safetyemporium.com
 www.safetyemporium.com



Due to continuing product improvement, the information contained in this document is subject to change without notice. All dimensions are ± 1/4" (6mm). rev. 022019