

○ **L4260-158FT** Laboratory Lift/Turn Ball Valve Assembly, Panel Mounted Single, Floating Escutcheon

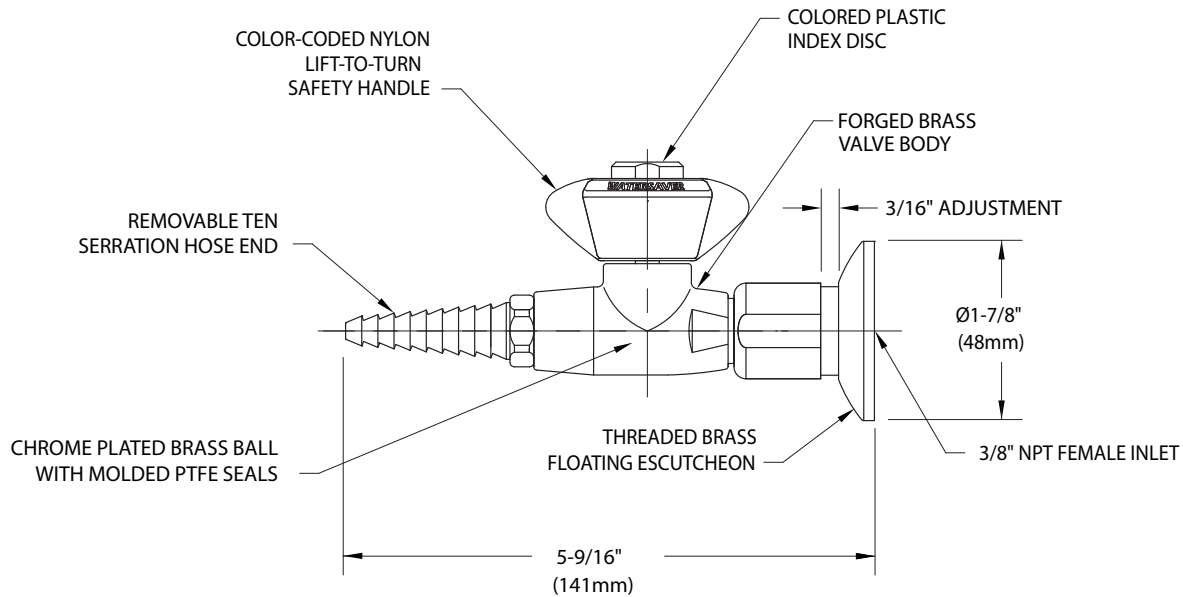

Distributed by:
 Safety Emporium
 PO Box 1003
 Blackwood, NJ 08012
 Ph: (866) 326-5412 toll-free
 Fax: (856) 553-6154
esupport@safetyemporium.com
www.safetyemporium.com



NOTES:

1. LABORATORY BALL VALVE ASSEMBLY IS CERTIFIED BY CSA INTERNATIONAL TO COMPLY WITH ANSI Z21.15 AND CGA 9.1.
2. HANDLE LOCKS IN CLOSED POSITION. LIFT HANDLE TO UNLOCK AND OPEN VALVE.
3. FIXTURE HAS FEMALE INLET FOR CONNECTION TO SUPPLY. FLOATING ESCUTCHEON IS THREADED TO WALL TO CONCEAL ANY GAP BETWEEN VALVE AND WALL.
4. FIXTURE IS FULLY ASSEMBLED AND FACTORY TESTED AT 125 PSI AIR PRESSURE. MAXIMUM WORKING PRESSURE IS 75 PSI.
5. SPECIFY IF CLEANING FOR OXYGEN AND HIGH PURITY GASES IS REQUIRED
6. FIXTURE HAS A POLISHED CHROME PLATED FINISH.

Measurements may vary $\pm 1/4$ ".