



ADP20 Air-Driven Free-Air® Pump

The only air-driven ambient air pump that can power a climate control device.

The convenient air-driven ADP20 Free-Air pump is an ideal alternate air source for supplied-air respirator users. The ADP20 is the best choice for users working in locations without an electrical power source (but compressed air is available). Alternatively, the ADP20 is also ideal for potentially explosive work environments that would require a costly, explosion-proof electrical motor.

Expensive carbon monoxide alarms may not be required as air from the



The Frigitrone® 2000 series air conditioner can cool incoming air by as much as 20°F (11°C).

Distributed by:
Safety Emporium
PO Box 1003
Blackwood, NJ 08012
Ph: (866) 326-5412 toll-free
Fax: (856) 553-6154
esupport@safetyemporium.com
www.safetyemporium.com

The ADP20 pump does not require CO monitors, alarms or calibration procedures.

drive compressor is not transferred to the worker. Rather, the pump should be located at a source of clean, fresh, ambient air which is filtered to remove certain particulates and then transferred to the worker. Compressed air at a minimum volume of 85 cfm at 95 psig (2407 lpm at 655 kPa) is used only as an energy source.

The powerful ADP20 pump is not only versatile but allows the use of a Bullard personal air conditioner to provide additional worker comfort and productivity. The pump provides 30 cfm of air operating at 5 psig (850 lpm at 34.5 kPa). Maximum pressure output is 25 psig (172.4 kPa).

Used without a personal air conditioner, the ADP20 pump can supply a continuous flow of air to up to six workers wearing supplied-air mask-type respirators or up to four workers wearing supplied-air hood-style respirators.

For enhanced worker comfort, the ADP20 can supply air to one worker using the Bullard Frigitrone® 2000 Series personal air conditioner in conjunction with a Bullard CC20 or 88 Series hood-style respirator. The Frigitrone can lower the temperature of the air supplied to the respirator hood by as much as 20°F (11°C) resulting in a more comfortable and productive worker.

ADP20 Air-Driven Ambient Air Pump Specifications

AIR FLOW: 30 cfm at 5 psig
(850 lpm at 34.5 kPa)

PUMP SPECIFICATION TABLE			
Pump Model No.	Maximum Number of Respirators		Maximum Outlet Air Pressure*
	Hood	Full/Half	
ADP20	Four	Six	25 psig (172.4 kPa)
ADP20 with Frigatron 2000 Series Air Conditioner	One	None	25 psig (172.4 kPa)

*USE ONLY SUPPLIED-AIR RESPIRATORS THAT ARE APPROVED BY MSHA/NIOSH TO OPERATE AT 25 PSIG (172.4 kPa) OR LESS.

The air motor requires a continuous supply of 85 cfm air volume at 95 psig (2407 lpm at 655 kPa) for optimum performance.

INLET FILTER: Medium efficiency, keeps particulates larger than 25 microns out of the air supply.

OUTLET FILTER: Carbofine with activated carbon.

WEIGHT: 90 lbs. (40.8 kg)

DIMENSIONS: 12 1/8" (31.3 cm) Wide x 25" (63.5 cm) Long x 15" (38.1 cm) High (41 1/2" (105.4 cm) High with Air Intake installed)

NOTE: Supplied-air respirators used with this ambient air pump must be MSHA/NIOSH approved to operate at 25 psig (172.4 kPa) or less. See respirator owner's manual for recommended air pressure requirements.

ORDERING INFORMATION

Cat. No.	Description
23611	Inlet Filter
S17101	Outlet filter cartridge
244852	Outlet filter jar
15922	Pump service kit (Includes four carbon vanes, 23611 inlet filter and S17101 outlet filter cartridge)
17761	Air motor service kit (Includes four carbon vanes, motor bearings, vane springs and seal)
S17931	Loctite® Safety Solvent, 12 oz. (340 g) aerosol can
21052	Conversion kit. Includes parts and instructions to convert ADP16 or ADP3CA pumps to ADP20.
S09853	Pressure gauge, motor, 0-230psig (0-1379 kPa)
S16222	Pressure gauge, pump, 0-35 psig (0-207 kPa)
V22	Quick-disconnect coupler adaptor. Converts pump's quick-disconnect coupler to double 3/8" femaleNPT
V23	Quick-disconnect coupler adaptor. Converts pump's quick-disconnect coupler to a single 3/8" femaleNPT
V24	Quick-disconnect coupler splitter/adaptor, converts pump's single outlet to a double 1/2" Industrial Interchange coupler (one flow-through, one shut-off)
V50IN	Remote inlet air hose kit, 50 feet (15.2 m) (one per pump)
V50EX	Remote extension hose kit, 50 feet (15.2 m) (five per pump maximum)

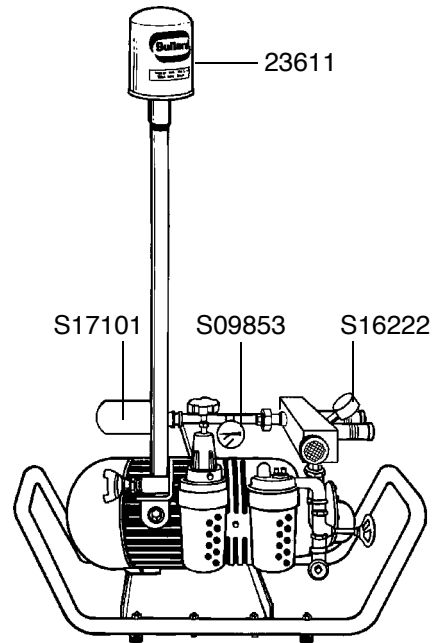

Distributed by:

⚠ WARNING ⚠

The ADP20 Free-Air® pump DOES NOT filter out carbon monoxide or other harmful or deadly gases. Only climate control devices manufactured by E.D. Bullard Company should be used with Bullard respirators. Substituting other climate-control tubes will expose the user to life threatening conditions, diseases, or death. Inlet air filter must be located where clean, breathable air is assured at all times, away from the source of any contaminants.

E.D. Bullard Company products are manufactured to exacting specifications. Any alteration or modification of these products by the user may adversely affect product performance. This data sheet is in summary form only for easy reference. Refer to labels, instructions, or other literature accompanying the product for complete details regarding use, maintenance, warnings, performance, complete specifications, instructions and precautions.

For more information or the nearest distributor, call toll free 800-827-0423.



1898 Safety Way
Cynthiana, KY 41031-9303
Phone: 606-234-6611
Facsimile: 606-234-6858
Toll-Free: 800-827-0423
Web Site: <http://www.bullard.com>

Free-Air and The Human Side of Safety are registered trademarks of E. D. Bullard Company.

Loctite is a registered trademark of the Loctite Corporation.

Copyright 1995 by E. D. Bullard Company. All rights reserved including the right of reproduction, in whole or in part, in any form.