

READ ALL INSTRUCTIONS BEFORE USING THIS PUMP

Table of Contents

GENERAL INFORMATION	1
WARNINGS	3, 4
PUMP COMPONENTS	5
BREATHING AIR REQUIREMENTS	6
ASSEMBLY AND INSTALLATION	
Assembling the Free-Air Pump	7
How Air Motor Works	7
How Motor Drives Pump	7
How Pump Supplies Air	7
Installation	7, 8
OPERATING THE FREE-AIR PUMP	9, 10
MAINTAINING THE FREE-AIR PUMP	
Maintaining the Air Motor	11
Maintaining the Pump	11, 12
Ensuring Pump Performance	12
TROUBLESHOOTING GUIDE	13
REPLACEMENT PARTS	14
PUMP WARRANTY	15
AIR FILTER REPLACEMENT SCHEDULE	16
AUTHORIZATION FOR RETURNED GOODS	17

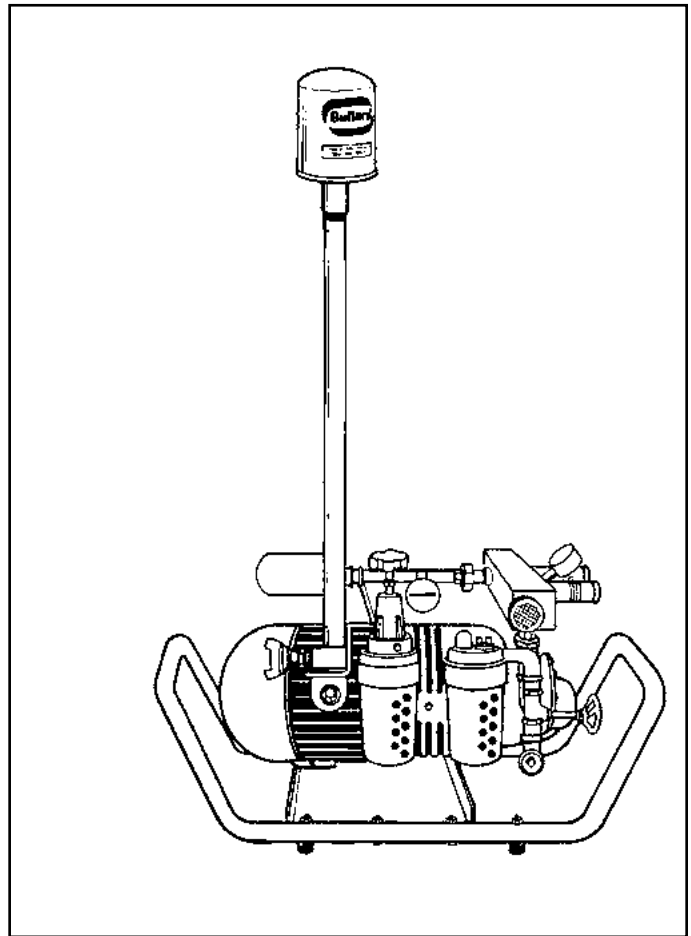

Distributed by:
 Safety Emporium
 PO Box 1003
 Blackwood, NJ 08012
 Ph: (866) 326-5412 toll-free
 Fax: (856) 553-6154
esupport@safetyemporium.com
www.safetyemporium.com

General Information

Bullard Free-Air Pumps transfer ambient air from a clean air location, where breath-able air can be assured at all times, to workers wearing Type C or CE continuous flow supplied-air respirator hoods or tight fitting half or full face masks.

The ambient air is filtered through a medium efficiency Inlet Air Filter and a Carbofine Outlet Filter before entering the respirator's air supply hose.

Bullard Free-Air Pumps are oil-less and have rotary carbon vanes. They produce no carbon monoxide, oil vapors, oil mist or moisture. They do not require expensive carbon monoxide monitors, high temperature alarms or airline filters. No calibration is required.

NOTE

Drive-Air pressure (psig) determines horsepower of air motor which directly affects output air pressure and output air volume. When operating a hood-style respirator with a Frigatron 2000 Series air conditioner incoming drive air pressure must be set at 95 psig for optimum pump performance. Attempting to operate a hood-style respirator with a Frigatron air conditioner with the incoming drive air at less than 95 psig may result in an inadequate supply of air to the worker. See below for pump performance.



On the charts below, find the relevant Output Air Pressure (psig) corresponding to the respirator's approved pressure range to determine the pump's total air volume (cfm) and a maximum number of respirators that can be used at that air volume.

Model ADP20 Pump Performance Table Incoming Drive-Air Pressure Maintained at 85 psig

Pump's Output Air Pressure (psig)	Pump's Output Air Volume (cfm)*	Maximum Recommended Mask Respirators**	Maximum Recommended Hood Respirators**	Recommended Hood Respirators with Frigatron Air Conditioner
5	24.0	Five	Three	None
10	18.0	Three	Two	None
15	14.0	Two	One	None
18	11.0	Two	One	None
20	8.5	One	One	None
22	7.0	One	None	None
25	4.0	None	None	None

* Assumes that no air is being dumped from the pressure relief valve and that pump's drive-air pressure is maintained at 85 psig.

** It should be noted that the minimum air flow required for each tight-fitting, mask-style respirator is four (4) cfm. A minimum airflow of six (6) cfm is required for each hood-style respirator.

The ratings which appear here, therefore, are conservative, but reflect Bullard Company's position that worker respiratory protection is enhanced when air flow available to the respirator wearer is above the NIOSH required minimums.

Model ADP20 Pump Performance Table Incoming Drive-Air Pressure Maintained at 95 psig

Pump's Output Air Pressure (psig)	Pump's Output Air Volume (cfm)*	Maximum Recommended Mask Respirators**	Maximum Recommended Hood Respirators**	Recommended Hood Respirators with Frigatron Air Conditioner
5	31.0	Six	Four	None
10	26.5	Five	Three	None
15	21.5	Four	Three	None
18	18.5	Three	Two	One
20	16.5	Three	Two	One
22	14.5	Three	Two	One
25	11.4	Two	One	One

* Assumes that no air is being dumped from the pressure relief valve and that pump's drive-air pressure is maintained at 95 psig.

** It should be noted that the minimum air flow required for each tight-fitting mask style respirator is four (4) cfm. A minimum airflow of six (6) cfm is required for each hood-style respirator.

The ratings which appear here, therefore, are conservative, but reflect Bullard Company's position that worker respiratory protection is enhanced when air flow available to the respirator wearer is above the NIOSH required minimums.

ADP20 Free-Air® Pump User Manual

▲ WARNING

READ ALL INSTRUCTIONS IN THIS MANUAL BEFORE USING FREE-AIR PUMP MODEL ADP20.

FAILURE TO OPERATE THIS PUMP IN ACCORDANCE WITH THE INSTRUCTIONS CONTAINED IN THIS MANUAL MAY RESULT IN DEATH OR SERIOUS INJURY TO THE RESPIRATOR WEARER.

1. LOCATE THE PUMP'S INLET AIR FILTER IN A PLACE WHERE THERE IS CLEAN, BREATHABLE AIR AT ALL TIMES. THE PUMP WILL NOT REMOVE TOXIC GASES OR OTHER CONTAMINANTS FROM THE INCOMING AIR IT TRANSFERS TO THE RESPIRATOR WEARER.
SEE THE BREATHING AIR REQUIREMENTS SECTION ON PAGE 4 FOR SPECIFIC DETAILS ON BREATHING AIR QUALITY.
2. THIS PUMP WILL SUPPLY AT LEAST THE REQUIRED MINIMUM VOLUME OF AIR (6 CFM FOR HOODS OR 4 CFM FOR TIGHT FITTING MASKS) TO LOW PRESSURE, AIRLINE RESPIRATORS. THE RESPIRATORS MUST BE APPROVED BY MSHA/NIOSH TO OPERATE AT LESS THAN 25 PSIG.
BE SURE THAT THE PUMP'S OUTLET PRESSURE, MEASURED BY THE PRESSURE GAUGE ON THE PUMP, IS MAINTAINED ABOVE THE MINIMUM PRESSURE SETTING REQUIRED BY THE RESPIRATOR MANUFACTURER.
TO BE ASSURED YOUR RESPIRATOR CAN BE USED WITH THIS PUMP, REFER TO THE SECTION IN THE RESPIRATOR'S INSTRUCTION MANUAL FOR THE RESPIRATOR'S APPROVED PRESSURE RANGE AND PERMISSIBLE AIR SUPPLY HOSE LENGTH.
IF YOU HAVE ANY QUESTIONS ABOUT WHETHER OR NOT YOUR RESPIRATOR IS COMPATIBLE WITH THIS PUMP, CONTACT BULLARD'S CUSTOMER SERVICE DEPARTMENT AT 877-BULLARD.
3. AIRLINE RESPIRATORS USED WITH THIS PUMP MUST NOT BE WORN IN ANY ATMOSPHERE IMMEDIATELY DANGEROUS TO LIFE OR HEALTH OR FROM WHICH THE WEARER CANNOT ESCAPE WITHOUT THE USE OF THE RESPIRATOR.
4. WHEN CONNECTING YOUR RESPIRATOR TO THE FREE-AIR PUMP, USE ONLY THE AIR SUPPLY HOSE AND COUPLINGS REQUIRED BY THE RESPIRATOR MANUFACTURER AND APPROVED BY MSHA/NIOSH.
USE OF NON-APPROVED HOSE OR COUPLINGS WILL VOID THE RESPIRATOR'S MSHA/NIOSH APPROVAL AND COULD REDUCE THE AIR FLOW TO THE RESPIRATOR, RESULTING IN POSSIBLE DEATH OR SERIOUS INJURY TO THE RESPIRATOR WEARER.
5. DO NOT MODIFY OR ALTER THIS PUMP IN ANY MANNER. USE ONLY APPROVED BULLARD FREE-AIR PUMP COMPONENTS AND REPLACEMENT PARTS ON THE PUMP.
FAILURE TO USE APPROVED BULLARD COMPONENTS AND REPLACEMENT PARTS INVALIDATES ALL BULLARD WARRANTIES AND MAY RESULT IN DEATH OR SERIOUS INJURY TO THE RESPIRATOR WEARER.
6. IF YOU HAVE ANY QUESTIONS CONCERNING THE USE OF THIS PUMP OR YOUR RESPIRATOR, OR YOU ARE NOT SURE THE INLET AIR FILTER IS LOCATED AT A SOURCE OF CLEAN, BREATHABLE AIR, ASK YOUR SUPERVISOR.

ALL INSTRUCTIONS FOR THE USE AND CARE OF THIS PRODUCT MUST BE SUPPLIED TO YOU BY YOUR EMPLOYER AS RECOMMENDED BY THE MANUFACTURER AND AS REQUIRED BY FEDERAL LAW (29 CFR 1910.134).

FOR TECHNICAL ASSISTANCE OR ADDITIONAL COPIES OF THIS MANUAL, CALL OR WRITE TO:

BULLARD
1898 SAFETY WAY
CYNTHIANA, KY 41031-9303
TOLL-FREE: 877-BULLARD (285-5273)
PHONE: 859-234-6616
FAX: 859-234-8987

Model ADP20 Pump Components

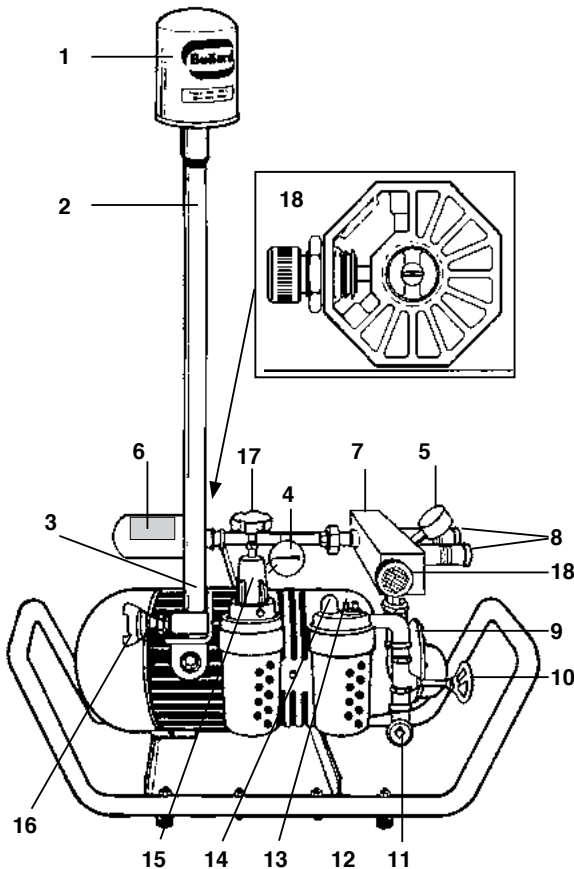

1. Inlet Air Filter 23611
2. Air Inlet Stand Pipe
3. Threaded Air Inlet Port
4. Gauge, Drive Air Pressure (0-200 psig) S09853
5. Gauge, Outlet Air Pressure (0-30 psig) S16222
6. Outlet Filter Cartridge S17101
7. Heat Exchanger
8. Quick-Disconnect Couplers, Female (1/2" industrial interchange) S16191
9. Air Motor
10. Throttle Valve
11. Plug
12. Lubricator
13. Oil Metering Screw
14. Oil Sight Dome
15. Pressure Regulator
16. Drive Air Inlet Claw Foot Connector
17. Regulator Knob
18. Outlet Pressure Adjustment Knob

Breathing Air Requirements

Air Quality

The Free-Air pump's inlet air filter **MUST** be located in a place where there is clean, breathable air at all times.

The breathable air drawn into the inlet filter must meet at least the requirements for Type 1 gaseous air described in the Compressed Gas Association Commodity Specifications G-7.1 (Grade D or higher), as specified by Federal Law 30 CFR, Part 11, Subpart J, 11.121 (b).

The requirements of Grade D breathable air include:

- Oxygen..... 19.5 - 23.5%
- Hydrocarbons (condensed) in mg/m³ of gas 5 mg/m³ maximum
- Carbon Monoxide 10 ppm maximum
- Carbon Dioxide..... 1,000 ppm maximum
- Odor No detectable odor
- No toxic contaminants at levels which would make the air unsafe to breathe.

Refer to the C.G.A. Commodity Specification G-7.1 for complete details. It is available from:

Compressed Gas Association
500 Fifth Avenue
New York, NY 10036

Assembly and Installation

For the specific location of the pump components referred to below, see the list of pump components to the left.

Assembling the Free-Air Pump

1. Remove assembly from plywood shipping board and attach four rubber feet through four holes in skid.
2. Install stand pipe (2), and Inlet AIR Filter (1) into threaded air inlet PORT (3).
3. Make sure the pump's inlet air filter is located in a clean, uncontaminated location where breathable air is assured at all times.

If the inlet air filter cannot be placed at a source of clean, breathable air, install Bullard's 50 foot Inlet Extension Hose Kit (Cat. No. V50IN) to the pump's inlet port. See the directions shipped with the Extension Hose Kit for assembly instructions.

If clean breathable air cannot be guaranteed at all times within this 50 foot reach, you may add up to five additional lengths of 50 foot Extension Hose (Cat. No. V50EX).

Therefore, you may place your Inlet Filter up to 300 feet (6 x 50) away from the pump. Do not add more than 300 feet of inlet extension hose to the pump.

How Air Motor Works

1. Compressed air enters through drive AIR INLET (16), passes through PRESSURE REGULATOR (15); where pressure is controlled and excess oil and water are removed.
Air pressure is adjusted with REGULATOR KNOB (17) and is read on GAUGE (4) (NOTE: 80 psig or higher during operation is normal for this motor).
2. Air passes through LUBRICATOR (12) where oil is added and metered.
3. Lubricated air passes through THROTTLE VALVE (10) and drives AIR MOTOR (9)
4. Air is exhausted through motor exhaust muffler (18) to atmosphere.

How Motor Drives Pump

Motor drives pump through a flexible coupler. There are no belts to maintain or tighten.

How Pump Supplies Air

Clean breathable air must be supplied to PUMP INLET AIR FILTER (1) at all times (See Breathing Air Requirements in the section above).

The pump draws in air using four sliding carbon vanes set in a rotor, and discharges it under low pressure out of discharge port.

ADP20 Free-Air® Pump User Manual

Air passes through Bullard's CARBOFINE OUTLET FILTER CARTRIDGE (6) located inside OUTLET FILTER HOUSING.

Bullard's CARBOFINE outlet filter is triple wrapped with activated carbon media and has a rayon overwrap.

The properties of this filter include:

- STOPS 99.97% ALL OIL AEROSOLS
- 99.97% D.O.P. EFFICIENCY (.3-.6 MICRON SIZE PARTICLES)
- MAXIMUM SOLID PARTICLE SIZE THAT WILL PASS THROUGH 0.3 MICRON
- MAXIMUM LIQUID PARTICLE SIZE THAT WILL PASS THROUGH 0.75 MICRON

As long as the customer has Grade D air going into the pump and the inlet and outlet filter are clean the pump should be working correctly and adheres to what is required.

NOTE: Change this outlet filter cartridge at least every 200 running hours.

Filtered breathing air passes out through one, two, or three COUPLERS (8) to one, two, or three airline respirators depending on the style of respirator(s) being used (See table, page 2).

NOTE: The two, 1/2" Industrial Interchange quick-disconnect couplers are supplied with the factory packed unit. You may replace these couplers to conform with the hose and respirator you are using.

Installation

NOTE: Use ample size hose from compressor to pump; 1" or 3/4" internal diameter is best. A larger diameter compressed air hose may be required depending on operating conditions and length of compressed air line.

The compressor must have capacity to continuously supply at least 85 cfm of air at 95 psig to drive the pump at its rated capacity.

1. With the pump shut off, fill LUBRICATOR (12) through fill cap with SAE 10 Automotive Engine Oil to fill line on bowl. Do not use a heavier grade oil than SAE 10. Be sure drain valve at bottom of regulator is closed
2. Close THROTTLE VALVE (10).
3. ATTACH HOSE WITH RESPIRATORS CONNECTED TO AIR OUTLETS (8) ON PUMP
4. Connect air supply to pump.
5. Adjust AIR REGULATOR so COMPRESSED AIR GAUGE (4) reads 95 psig.
6. Pump is ready to run. Open THROTTLE VALVE (10), build up speed and idle for a few minutes.
7. Adjust THROTTLE VALVE (10) to run pump at desired psig on OUTLET AIR PRESSURE GAUGE (5) and adjust OIL METERING SCREW (13) until lubricator is producing approximately 1 DRIP PER MINUTE in the SIGHT DOME (14).

NOTE: This drip rate should be monitored occasionally during operation.

8. Adjust RELIEF-VALVE as follows:

NOTE: The RELIEF VALVE is preset at the factory to "bleed off" at 25 psig.

- a. Loosen lock nut.
- b. Pinch off respirator air supply hose to create back pressure.
- c. Speed up motor by opening throttle valve.
- d. Adjust relief-valve to "bleed off" at a pressure 1 or 2 psig above that required by respirator.
- e. Slow down motor and check that no air "bleeds" below required pressure.
- f. Maximum output operating pressure is 25 psig.

NOTE: Pump will reach 150° - 200° F during normal running conditions.

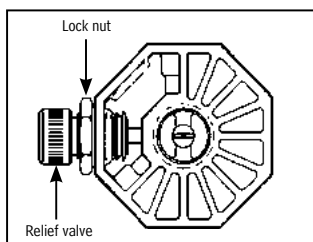

Operating the Free-Air Pump

▲ WARNING

THE RESPIRATOR USER MUST NOT ENTER THE CONTAMINATED WORK AREA UNTIL ALL OF THE FOLLOWING STEPS HAVE BEEN COMPLETED.

1. Analyze the atmosphere at the location of the pump's air inlet filter. The inlet filter should be located in a clean, uncontaminated location where breathable air is assured at all times. The pump is equipped with a 2 ft. stand pipe to keep the intake away from the air motor exhaust port.

If the inlet filter cannot be placed at a source of clean, breathable air, install Bullard's 50 foot Inlet Extension Hose Kit (Cat. No. V50IN) to the pump's inlet port. See the directions shipped with the Extension Hose Kit for assembly instructions.

If clean breathable air cannot be guaranteed at all times within this 50 foot reach, up to five (5) additional lengths of 50 foot Extension Hose (Cat. No. V50EX) may be added.

Therefore, the inlet filter may be placed up to 300 feet (6 x 50) away from the pump. Do not add more than 300 feet of inlet extension hose to the pump.

2. Be sure you have read and followed all instructions for assembly and installation of the ADP20 pump on pages 4 and 5.
3. Pump Model ADP20 will operate sitting on its four rubber mounts. It does not need to be bolted down.
4. Assemble your respirator by following the manufacturer's directions as described in the respirator's Instruction Manual. Be sure the pump's outlet pressure, measured by the pressure gauge on the pump, is greater than the minimum MSHA/NIOSH approved pressure required to operate the respirator.

The respirator's minimum approved pressure will be found in the respirator's Instruction Manual and/or on labels attached to the respirator.

If you have any questions as to whether or not your respirator is compatible with this pump, call Bullard's Customer Service Department at 877-BULLARD.

5. Connect the respirator's MSHA/NIOSH-approved air supply hose(s) to the quick-disconnect Outlet Coupling(s) on the pump.

A. OUTLET COUPLING

If your respirator's air supply hose(s) have 1/2" Industrial Interchange quick-disconnect fittings and you want to supply air to one or two hood, full face or half mask respirators you may connect them directly to the two female 1/2" quick-disconnect couplers on the pump.

If you want to supply air to three full or half mask respirators (the pump does not provide sufficient air volume for three hoodstyle respirators), you may purchase and install an additional female quick-disconnect coupling (Cat. No. S16191).

B. CONNECTING AIR SUPPLY HOSE(S) WITHOUT 1/2" QUICK-DISCONNECT FITTINGS

If your respirator's MSHA/NIOSH-approved air supply hose will not attach to the pump's standard 1/4" Industrial Interchange Outlet Couplings, (see above) the hose fitting can be adapted to the pump by converting the pump's quick-disconnect outlet to 3/8" female NPT with the installation of one or more of the following adaptors.

Cat. No. V23 - Converts SINGLE outlet to SINGLE 3/8" female NPT pipe thread.

Use Teflon tape or pipe thread sealer to ensure an air tight seal.

A variety of quick-disconnect fittings may then be used to connect the air supply hose to the 3/8" outlet adaptor. Contact your respirator's manufacturer for the proper fitting (Hansen, Parker, Snap-Tite, Schrader, etc.)

6. Before connecting your respirator to the air supply hose, turn the pump on. Allow the air to flow through the pump and hose for a few minutes to purge or expel any hose odors or moisture that may have accumulated inside the hose.

7. Connect the respirator to the air supply hose using the quick-disconnect fittings.
8. Set the pump's outlet pressure to within the respirator's approved pressure range by adjusting the THROTTLE VALVE (10).
9. With the air flowing, put on the respirator by following the directions in the respirator manufacturer's Instruction Manual.

YOU ARE NOW READY TO ENTER THE WORK AREA.

10. When finished working, leave the work area wearing the respirator with the air still flowing. Once outside the contaminated area, remove the respirator, turn the pump off, then disconnect the air supply hose using the quick-disconnect couplings.

See the respirator's Instruction Manual for proper inspection, maintenance and storage procedures for the respirator you are using.

Maintaining the Free-Air Pump

FOR THE PUMP TO OPERATE AT ITS OPTIMUM PERFORMANCE LEVEL, THE FOLLOWING ROUTINE MAINTENANCE PROCEDURES MUST BE PERFORMED.

FOR THE SPECIFIC LOCATION OF THE PUMP COMPONENTS REFERRED TO BELOW, SEE THE LIST OF PUMP COMPONENTS ON PAGE 4.

Maintaining the Air Motor

The air motor is a rotary 4-vane type. The vanes require no adjustment and will last 5,000-15,000 hours if properly maintained.

1. Maintain INLET AIR PRESSURE REGULATOR FILTER (15):
 - It is equipped with a 40-micron filter element that can plug up if air supply is not prefiltered at the compressor.
 - Remove and clean filter periodically to prevent clogging.
2. Maintain LUBRICATOR (12):
 - Keep filled with SAE 10 Automotive oil. (Do not use a heavier grade)
 - Maintain drip rate at approximately 1 per minute.
 - DO NOT fill while running or while under pressure
3. Flush MOTOR (9):

If motor is sluggish or inefficient, flush with LOCTITE SAFETY SOLVENT, or any non-toxic, nonflammable industrial cleaning solvent).

Use the following directions to flush the motor:

 - a. Shut-off the pressure into the air motor and disconnect the airline from the DRIVE AIR INLET (16).
 - b. Locate the pump in a safe area. Solvent will spray from the exhaust port during flushing. Protect your face and eyes from the spray.
 - c. Remove the PLUG (11) and pour several teaspoons of solvent into the opening.
 - d. Replace the PLUG, reconnect the airline back to the DRIVE AIR INLET. Turn the pressure back on. Run the pump at a very low speed (10-20 RPM) for approximately one minute or until all the solvent is flushed.

NOTE: Motor bearings are grease packed and sealed. They require no maintenance.

Maintaining The Pump

Pump is rotary 4 vane type. The vanes require no adjustment and will last 5,000 to 10,000 hours if properly maintained.

1. Maintain FILTERS
 - Dirty filters restrict outlet air flow and can cause the motor to overload or cause premature pump failure.
 - Replace CARBOFINE OUTLET FILTER CARTRIDGE (6) at least once every 200 running hours (Catalog No. S17101).
 - Replace INLET FILTER (1) at least once every 500 running hours to maintain proper pressure and full air flow. To check the filter - while running the pump, momentarily remove the FILTER (1) from the INLET PIPE (2). If the

motor speeds up or the outlet pressure shown on GAUGE (5) increases, the filter needs replacement.

2. Flush PUMP if necessary

Should dirt, foreign particles, moisture or oil be permitted to enter, the vanes will become sluggish, resulting in a lowering of outlet air pressure. Flush the pump with LOCTITE SAFETY SOLVENT. (DO NOT USE KEROSENE).

Pump should be operated for at least a few minutes every one to two weeks to reduce the likelihood of rust film forming in the rotor.

If pump remains idle in humid environment for some time, FLUSHING may be required to remove rust film in chamber and rotor slots.

Use the following directions to flush pump:

- a. Turn-off THROTTLE VALVE (10) to stop the pump before flushing.
- b. Before flushing, disassemble and remove the following parts from the pump:
 - Respirator air supply hose(s)
 - Inlet Filter and Pipe Stand
 - Outlet Filter Jar and Outlet Filter
- c. With the pump running, pour several teaspoons of solvent into the pump's inlet port. Repeat the flushing if necessary.

WARNING

RUN THE PUMP FOR A SUFFICIENT TIME TO PURGE ALL TRACES OF THE SOLVENT BEFORE REPLACING THE FILTERS, RECONNECTING THE AIR SUPPLY HOSE(S) AND USING THE RESPIRATOR.

3. AVOID EXCESSIVE SPEEDS and PRESSURE
 - Avoid running above the 25 psig range for any length of time.

NOTE: NEVER lubricate this oil-less pump. BEARINGS are grease packed and sealed. They require no further lubrication.

Ensuring Pump Performance

To make sure your pump will perform properly:

1. Always locate the pump's air inlet in a clean, breathable air environment.
2. DO NOT contaminate inlet air with exhaust air from air motor
3. Change OUTLET FILTER every 200 running hours.
4. Make sure RELIEF VALVE is fully seated (no bleed-off).
5. Make sure LUBRICATOR is full and is functioning (1 drop per minute).
6. Always check Respirator Air Supply Hoses to make sure they are free of kinks.
7. Set incoming compressed drive air at 85 psig or higher. Set output air pressure as specified in respirator owner's manual.

See charts on pages 1 and 2 for pump performance. If operating hood with Frigatron 2000 Series air conditioner, incoming compressed driven air must be set at 95 psig or higher.

Troubleshooting Guide

OUTLET PRESSURE TOO HIGH

- Adjust THROTTLE VALVE (10)
- Check for kinked air supply hoses
- Reset pressure adjustment valve

OUTLET PRESSURE TOO LOW

- Adjust THROTTLE VALVE to increase motor speed
- Check for clogged INLET FILTER

ADP20 Free-Air® Pump User Manual

- Check that outlet filter jar is screwed on tight
- Check for clogged OUTLET FILTER
- Check pressure relief valve and adjust if necessary
- Check drive air inlet pressure
- Check for leaks in air hose
- Verify proper pressure range for your respirator
- Verify that respirator and hose are connected when gauge reading is taken
- Check to see that gauge is functioning properly
- Flush pump with LOCTITE SAFETY SOLVENT

RESPIRATOR AIR TEMPERATURE TOO HIGH (ABOVE AMBIENT)

- Air supply hoses coiled too tightly. Uncoil at least the first 50 feet of hose.
- Place portion of air supply hose in large container of ice (e.g. 30 gallon trash can).
- Keep air supply hoses out of direct sunlight or other heat sources.

Replacement Parts

Cat. No. Description

OPTIONAL PUMP ACCESSORIES

V50IN	Remote INLET air hose kit (50 feet) with remote inlet filter and pump fittings
V50EX	Extension hose kit (50 foot sections) for above
S17931	LOCTITE SAFETY SOLVENT (pump or motor)

NOTE: If breathable air cannot be assured at all times at the pump, remove inlet filter and attach necessary V50 hose kits to air inlet port. Use up to 300 feet (six lengths) always ending with V50IN kit. These hose kits can provide access to a remote "clean air" location.

REPLACEMENT PUMP PARTS

S16222	Gauge, Air (0-30 psig)
S17101	Bullard CARBOFINE outlet filter cartridge
23611	Inlet filter
244852	Outlet filter jar (aluminum jar only)
263552	Outlet filter assembly o-ring (10 per pkg.)
21052	Conversion kit
V15	Coupler, 1/4" Industrial Interchange, with male 3/8" NPT
V23	Quick disconnect
V19	Coupler, 1/4" Snap-Tite with 1/4" female pipe thread FPT
V23	Quick-disconnect coupling adaptor, SINGLE 3/8" female NPT
S16191	Coupler, 1/2" Industrial Interchange, with 3/8" male NPT
S15922	Pump repair kit (includes four carbon vanes, one 23611 inlet filter, one S17101 outlet filter cartridge and instructions)

AIR MOTOR REPLACEMENT PARTS

S09853	Gauge (0-200 psig)
17761	Motor repair kit (includes four carbon vanes, two motor bearings, vane springs, seal and instructions)

NOTE: Pump and motor repair requires use of a 3-prong wheel puller, a gear puller and an experienced mechanic. It may be quicker and less expensive to ship pump and/or motor to Bullard for repairs. See Authorization for Returned Goods, page 8)

Pump Warranty

Free-Air Pump One Year Limited Warranty

The Bullard warrants to the original purchaser that the Free-Air Pump will be free of defects in material and workmanship under normal use and service for a period of one (1) year from the date of purchase. Bullard's obligation under this warranty is limited to repairing or replacing, at its option, articles that are returned within the warranty period and that are, after examination, shown to Bullard's satisfaction to be defective, subject to the following limitations.

- Free-Air Pump must be returned to the Bullard factory with shipping charges prepaid.
- Free-Air Pump must not have been misused, subjected to negligent use, or damaged in transport.
- The date of purchase is the start of the one year warranty period. (A copy of the purchaser's original invoice showing the date of purchase is required to validate warranty coverage.)

In no event shall Bullard be responsible for damages for loss of use or other indirect, incidental, consequential or special costs, expenses or damages incurred by the purchaser, notwithstanding that Bullard has been advised of the possibility of such damages.

ANY IMPLIED WARRANTIES, INCLUDING WARRANTIES OF MERCHANTABILITY AND FITNESS FOR A PARTICULAR PURPOSE, ARE LIMITED IN DURATION TO ONE (1) YEAR FROM THE DATE OF PURCHASE OF THIS PRODUCT.

Some states do not allow the exclusion or limitation of incidental or consequential damages, or allow limitations on how long an implied warranty lasts, so the above limitations or exclusions may not apply to you. This warranty gives you specific legal rights, and you may have other rights which vary from state to state.

TO RETURN GOODS: Written permission must be obtained before returning any material for any reason whatsoever (See Authorization for Returned Goods on page 8).

Products which are obsolete or made to special order may not be returned.

Warranty information can be obtained from:

BULLARD
1898 SAFETY WAY
CYNTHIANA, KY 41031-9303
TOLL-FREE: 877-BULLARD (285-5273)
PHONE: 859-234-6616
FAX: 859-234-8987

Air Filter Replacement Schedule

Regular inspection and replacement of the air filters will prevent extensive and costly pump repairs. Dirty or clogged filters can be responsible for failure of the pump to build up outlet pressure and eventual overheating.

- Replace the Carbofine Outlet Filter Cartridge (Cat. No. S17101) at least once every 200 running hours or sooner if necessary.
- The Outlet Filter Cartridge is multi-layered with 40-micron size particles of activated carbon, a sorbent bed with an exposed carbon surface of more than 15,000 square feet.
- Vapor Removal Efficiency: 90-95%
 - D.O.P Efficiency: (0.3 to 0.6 Micron Particles) 99.97%
 - Solid Particle Filtering: 0.2 Micron and Larger.
 - Liquid Particle Filtering: 0.75 Micron and Larger
- Replace the medium efficiency Inlet Filter (Cat. No. 23611) at least once every 500 running hours or sooner if necessary.

The Inlet Filter keeps moisture as well as particulates larger than 25 microns out of the air supply and helps protect the pump's carbon vanes.

We recommend the chart on the back page be used to monitor and maintain a routine air filter replacement schedule.



Authorization for Returned Goods

IMPORTANT: BULLARD WILL DECLINE TO ACCEPT ANY RETURNED GOODS SHIPMENT UNLESS YOU HAVE FIRST FOLLOWED ALL OF THE STEPS OUTLINED BELOW.

To return goods to Bullard for repair, or replacement, whether under the terms of Bullard's warranty provisions or for paid repairs, you MUST:

1. Contact Bullard's Customer Service Department by telephone or in writing at:

BULLARD
 1898 SAFETY WAY
 CYNTHIANA, KY 41031-9303
 TOLL-FREE: 877-BULLARD (285-5273)
 PHONE: 859-234-6616
 FAX: 859-234-8987

Describe the nature of the problem you are experiencing. A Bullard Customer Service Representative may contact you for additional information or may attempt to help you resolve the problem over the telephone.

2. Upon determining that the product should be returned, Customer Service will provide you with written permission to return the product to Bullard. This will

include information which must be included on the shipping carton for proper receiving and handling by Bullard. DO NOT return product without first following this procedure.

3. Prior to packing the product for return shipment to Bullard, be certain that it has been fully decontaminated and cleaned of any hazardous materials which may have settled on the product during use. It is against the law to ship hazardous or contaminated materials. Bullard may refuse to accept the return of any product suspected of being contaminated.
4. Products returned, including those under warranty, must be shipped with all transportation charges prepaid. Bullard cannot accept any returned products delivered on a "freight-collect" basis.
5. Material returned will be subjected to factory inspection. Repair work that is deemed necessary, but which is not covered by warranty, will be performed at your expense. Bullard will attempt to provide a best estimate of such charges, but will invoice based upon work performed.

Routine Air Filter Replacement Schedule

CARBOFINE OUTLET FILTER CARTRIDGE (Cat. No. S17101)			MEDIUM EFFICIENCY INLET FILTER (Cat. No. 23611)		
Cumulative Pump Operating Hours	Last Filter Replacement Date	Employee Responsible (Initials)	Pump Operating Hours	Cumulative Last Filter Replacement Date	Employee Responsible (Initials)
200			500		
400			1,000		
600			1,500		
800			2,000		
1,000			2,500		
1,200			3,000		
1,400			3,500		
1,600			4,000		
1,800			4,500		
2,000			5,000		

Americas:
Bullard
 1898 Safety Way
 Cynthiana, KY 41031-9303 • USA
 Toll-free within USA: 877-BULLARD (285-5273)
 Tel: +1-859-234-6616
 Fax: +1-859-234-8987

Europe:
Bullard GmbH
 Lilienthalstrasse 12
 53424 Remagen • Germany
 Tel: +49-2642 999980
 Fax: +49-2642 9999829

Asia-Pacific:
Bullard Asia Pacific Pte. Ltd.
 LHK Building
 701, Sims Drive, #04-03
 Singapore 387383
 Tel: +65-6745-0556
 Fax: +65-6745-5176



©2014 Bullard. All rights reserved.
 Free-Air is a registered trademark of Bullard.