



NOTE:
Kit contains parts for repair of air-drive-motor only- (Order Cat. No. 15922 for repair kit for pump_end of assembly).

Kit Contains

(See Reference Numbers on Drawings.)

- 4 - Composition vanes (4)
- 4 - Vane springs (5)
- 2 - Push pins (6)
- 1 - Drive end bearing (7)
- 1 - Dead end bearing (8)
- 1 - Shaft seal (11)
- 2 - Body gaskets (13)
- 1 - O-Ring (15)
- 1 - End cap gasket (17)

General

This air motor is precision built. The top clearance between ROTOR and BORE is .0015". End clearance between sides of rotor and end plates is .0035".

The 4 vanes take-up their own wear and will last 5,000 to 15,000 hours with proper use and maintenance:

- a. Use of Bullard's Micro-mist lubricator-adjusted to approximately 1-drop of recommended oil/minute.
- b. Properly adjusted INLET pressure - 60 psig (or see manual).
- c. Correct operating speed as determined by monitoring OUTLET pressure - 10 to 15 psig (or see manual).
- d. Leaving lubricated during shut-down periods.

Vane Replacement

An experienced mechanic may accomplish this easily:

1. Remove outboard end plate (2) (opposite the drive shaft end).
Use a PULLER TOOL. Do not pry with screwdriver - this will dent the end plate and body causing leaks.
2. Clean chamber and rotor with approved solvents only.*
3. Lubricate chamber with a squirt of oil.
4. Install new vanes with the NOTCHED EDGE towards the bottom of the slot.

Distributed by:
Safety Emporium
PO Box 1003
Blackwood, NJ 08012

Ph: (866) 326-5412 toll-free
Fax: (856) 553-6154
esupport@safetyemporium.com
www.safetyemporium.com

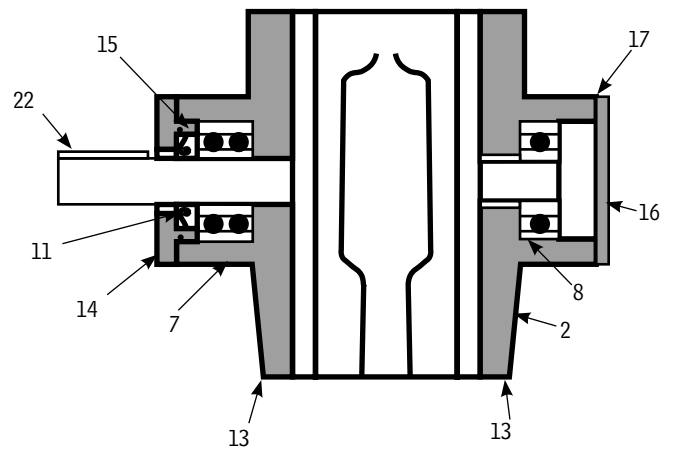
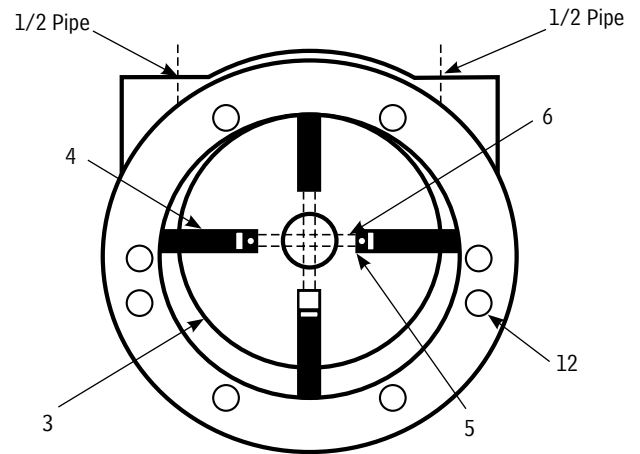

Complete Rebuild

1. Remove both SKIDS.
2. Remove MOTOR GUARD (#16, Figure 8 in owner's manual).
3. Disconnect WOOD'S coupling (Allen screws).
4. Remove motor from housing.
5. Replace all items provided in kit (bearings, seals, gaskets, etc.)

* Recommended solvents: Cleaning Solvent available as Bullard Cat. No. S17931, INHIBISOL Safety Solvent, DOW Chemical Chloroethane, or any non-toxic, non-flammable, industrial cleaning solvent.

Americas:
E.D. Bullard Company
1898 Safety Way
Cynthiana, KY 41031-9303
Toll free: 877-BULLARD (285-5273)
Tel: 859-234-6616
Fax: 859-234-8987
www.bullard.com

Europe:
Bullard GmbH
Lilienthalstrasse 12
53424 Remagen • Germany
Tel: +49-2642 999980
Fax: +49-2642 9999829
www.bullardextrem.com

Asia-Pacific:
Bullard Asia Pacific Pte. Ltd.
LHK Building
701, Sims Drive, #04-03
Singapore 387383
Tel: +65-6745-0556
Fax: +65-6745-5176
www.bullard.com



©2011 Bullard. All rights reserved.
Free-Air is a registered trademark of Bullard.