

# FOAM SYSTEMS MOBILCART

## Data/Specifications



### FEATURES

- Mobile; highly maneuverable
- Ready for instant operation
- Simple to use

### APPLICATION

The Mobilcart is designed to provide mobile firefighting foam capability for various hazardous areas where flammable liquids are present. Common applications include:

- Tank Farms and Refineries
- Loading Areas
- Chemical Processing Plants
- Diked Areas
- Warehouse Facilities
- Paint Storage Areas
- Any Other Manufacturing Areas Where Flammable Liquids are a Hazard

A broad range of foam concentrates can be used for these applications including ANSULITE® AFFF, Alcohol Resistant AFFF, JET-X® high expansion type, and protein based foam concentrates. Generally, the types of flammable liquids involved and the hazard configuration will best suit a particular type of Class B foam concentrate.

For hazards involving Class A fuel fires including wood, paper, coal, and rubber, a proportioning setting of 1% is recommended for use with SILV-EX® "Class A" Fire Control Concentrate.

### DESCRIPTION

- ▶ The Mobilcart is a highly maneuverable wheeled cart consisting of a 36 gallon (140 L) polyethylene tank with two built-in hose storage locations, eductor with metering valve, and two lengths of 50 ft. (15.2 m), 1 3/4 in. fire hose with choice of foam nozzle. Simply connect to water supply, turn on water, set the eductor metering valve as necessary, and direct the nozzle foam stream. It can be easily transported and operated by one person.

The Mobilcart will supply foam under a wide range of water pressures. Nozzle range is dependent upon the available flowing water pressure and the type of nozzle selected. Flow performance information is given in the following table.

#### Performance Table

Eductor	Water Inlet psi (Bar)	Flow gpm (lpm)	Approximate Operating Time (Minutes)		
			1%	3%	6%
Z-2	125 (8.6)	51 (193)	60	20	11
Z-2	150 (10.3)	55 (208)	57	19	10
Z-2	175 (12.0)	60 (227)	52	17	9
Z-4	125 (8.6)	101 (382)	31	10	5.5
Z-4	150 (10.3)	111 (420)	28	9	5
Z-4	175 (12.0)	120 (454)	26	8.5	4.5



007063

### SPECIFICATION

- ▶ The Mobilcart consists of a 36 gallon (140 L) polyethylene foam tank with built-in hose storage compartment. The chassis is constructed of painted steel tubing. The eductor is a brass 2 in. (5 cm) Model Z-2 or Z-4 complete with pick-up tube and metering valve for adjustment from 1% to 6% proportioning. Two 50 ft. (15.2 m) lengths of coupled 1 3/4 in. double-jacket fire hose with aluminum fittings are included. Nozzle choices are the matching KR-S2 or KR-S4 low-expansion foam nozzle, the KR-M2 or KR-M4 medium-expansion handline nozzle, or the Elkhart Chief Waterfog nozzle.

### ORDERING INFORMATION

Ansul Part No.	Description	Shipping Weight	
		lb.	(kg)
429952	MOBILCART (36 gal.)/60 gpm, Low Exp. KR-S2 Nozzle	180	(82)
429953	MOBILCART (36 gal.)/60 gpm, Med. Exp. KR-M2 Nozzle	180	(82)
429954	MOBILCART (36 gal.)/60 gpm, Waterfog Nozzle	180	(82)
429955	MOBILCART (36 gal.)/120 gpm, Low Exp. KR-S4 Nozzle	180	(82)
429956	MOBILCART (36 gal.)/120 gpm, Med. Exp. KR-M4 Nozzle	180	(82)
429957	MOBILCART (36 gal.)/120 gpm, Waterfog Nozzle	180	(82)

**NOTE:** Foam concentrate is not included with the Mobilcart and must be ordered separately. Optional components such as fittings and nozzles are available upon request.

Distributed by:  
Safety Emporium  
PO Box 1003  
Blackwood, NJ 08012

Ph: (866) 326-5412 toll-free  
Fax: (856) 553-6154  
esupport@safetyemporium.com  
www.safetyemporium.com

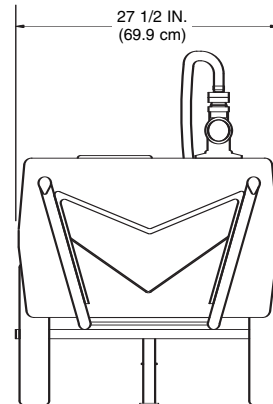
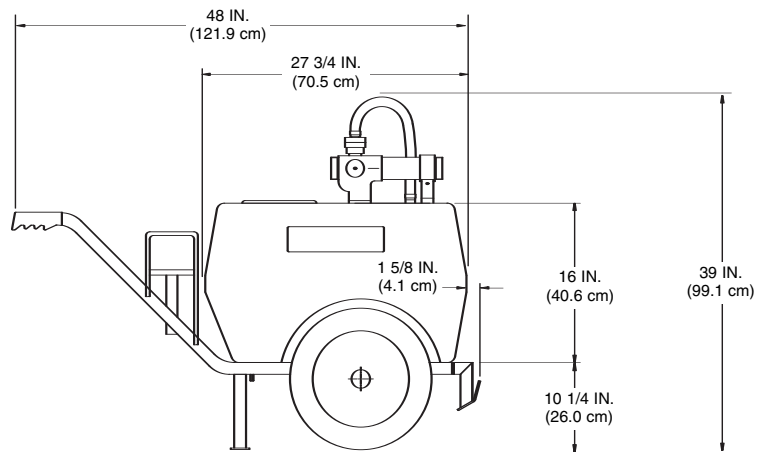

007062

ANSUL, ANSULITE, JET-X and SILV-EX are trademarks of Ansul Incorporated or its affiliates.



Ansul Incorporated  
Marinette, WI 54143-2542

715-735-7411  
www.ansul.com

Copyright ©2005 Ansul Incorporated  
Form No. F-93214-2