



AP250-008T Triangular Safety Station Sign

Application: Identify emergency safety stations. Three-sided ABS plastic for maximum visibility with ANSI-compliant graphics.

Mounting: Affix to vertical piping with included installation hardware.

Contents: One sign, four standoffs and screws, two mounting brackets, and two pipe clamps.

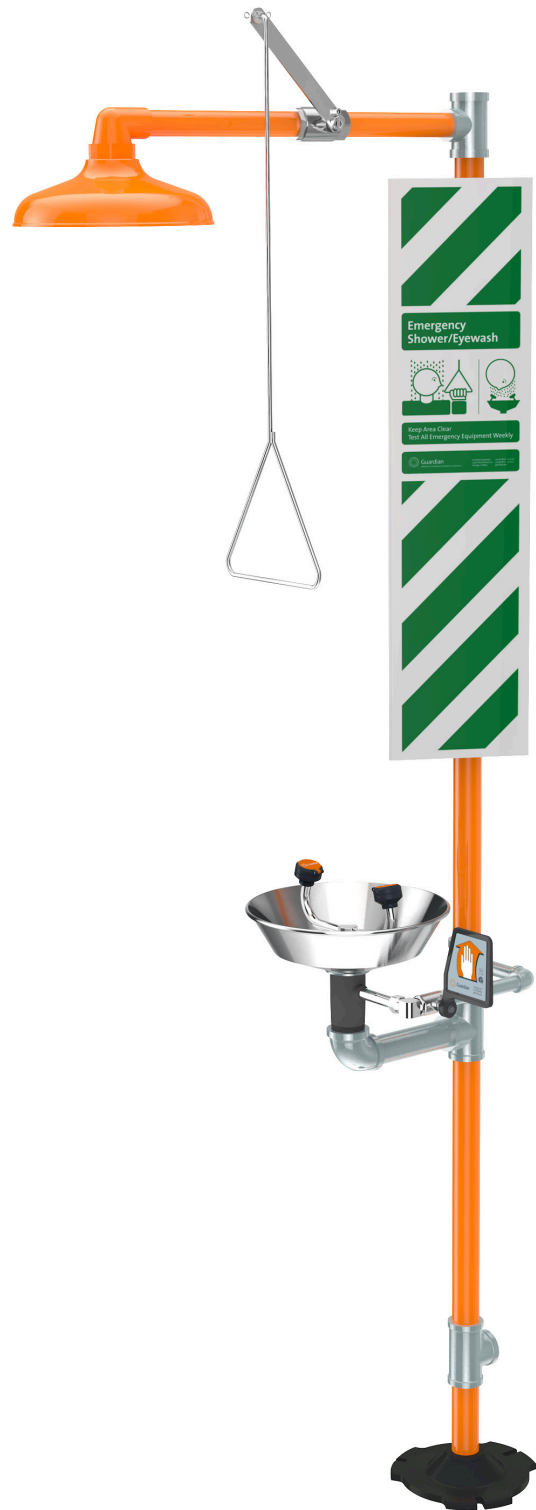

Distributed by:
Safety Emporium
PO Box 1003
Blackwood, NJ 08012
Ph: (866) 326-5412 toll-free
Fax: (856) 553-6154
esupport@safetyemporium.com
www. safetyemporium.com



AP250-008T Triangular Safety Station Sign

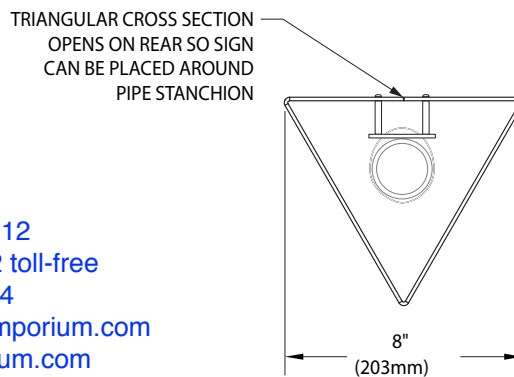
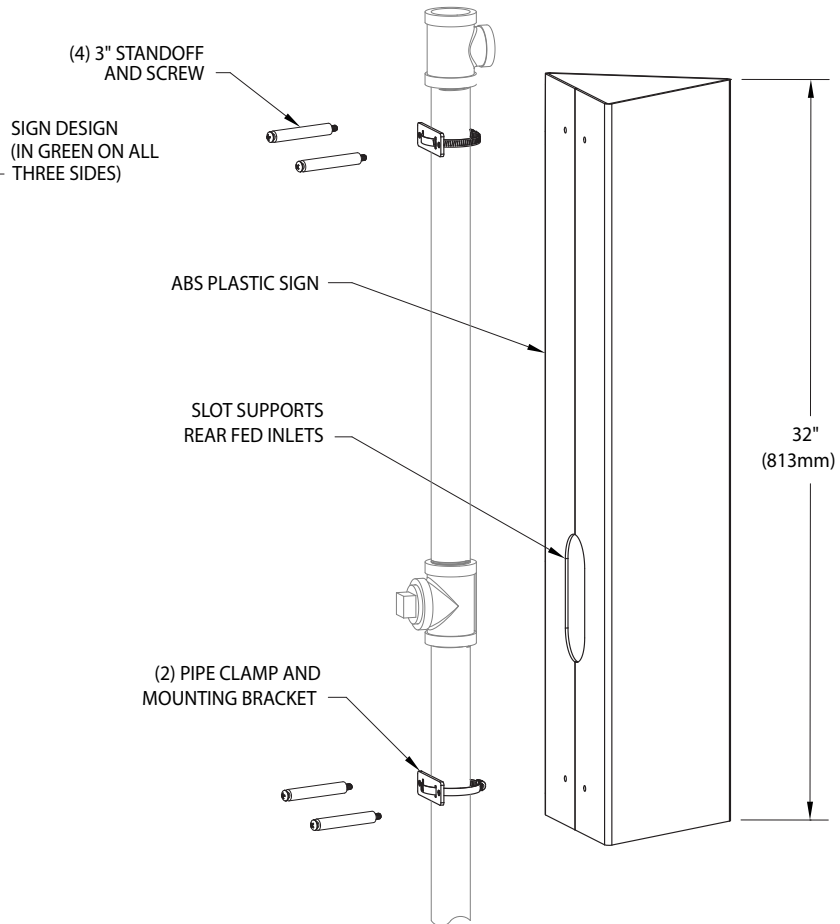

Distributed by:
Safety Emporium
PO Box 1003
Blackwood, NJ 08012
Ph: (866) 326-5412 toll-free
Fax: (856) 553-6154
esupport@safetyemporium.com
www.safetyemporium.com

THIS SPACE FOR ARCHITECT/ENGINEER APPROVAL

Due to continuing product improvement, the information contained in this document is subject to change without notice. All dimensions are $\pm 1/4"$ (6mm). rev. 0215