



### □ G3902LF Tempering Valve, 81 Gallon Capacity, Surface Mounted Stainless Steel Cabinet

**Application:** Tempering valve to blend hot and cold water to deliver tepid water. Valve has flow capacity of 3.0 to 81 gallons per minute (GPM). Valve can be used with single installation of emergency showers and safety stations, and with multiple installations of emergency shower, eyewash, eye/face wash, dual purpose eyewash/drench hose, drench hose and safety station units.

**Temperature Control:** Valve has bimetallic thermostat that senses incoming water temperature and automatically blends water to 85°F (29°C). High temperature limit stop is set to 90°F (32°C). Valve has dial thermometer on outlet to monitor temperature of delivered water. *Note: Valve may need to be adjusted when installed based on incoming water temperature. Refer to "Installation Instructions" for further information.*

**Fail Safe:** In event of restriction or failure of hot water supply, internal bypass allows valve to deliver cold water to emergency unit. In bypass mode, valve will deliver 40 GPM of cold water at 30 PSI flow pressure. In event of loss of cold water supply, valve will close and not deliver water.

**Flow Capacity:** Refer to chart below for flow capacity of valve at specified pressure drops:

System Pressure Drop (PSI)	5	10	15	20	25	30	35	40
Flow Rate (GPM)	53	64	72	81	90	99	108	117

System Pressure Drop (Bar)	.3	.7	1.0	1.4	1.7	2.4	2.4	2.8
Flow Rate (Liters per Minute)	201	242	273	307	341	374	409	443

**Supply Temperature:** Minimum hot water supply temperature is 140° F (60° C).

**Supply Pressure:** 30 PSI minimum supply pressure is required for proper operation of valve. Maximum supply pressure is 125 PSI. Maximum hot to cold water pressure differential is 5%.

**Mounting:** Tempering valve is mounted in 16 gauge Type 304 stainless steel surface mounted cabinet. Cabinet has hinged door with lock.

**Inlets:** 1-1/4" NPT female hot and cold water inlets. Inlets can be rotated 360 degrees for top or bottom supply. Each inlet has integral water strainer, check valve and supply stop.

**Outlet:** 1-1/2" NPT female outlet.

**Quality Assurance:** Valve is completely assembled and water tested prior to shipment. Valve is certified to meet low lead requirements of wetted surface area less than 0.25% lead by weight.

### Additional Model

□ G3907LF Same as above except valve is installed in recess mounted stainless steel cabinet.

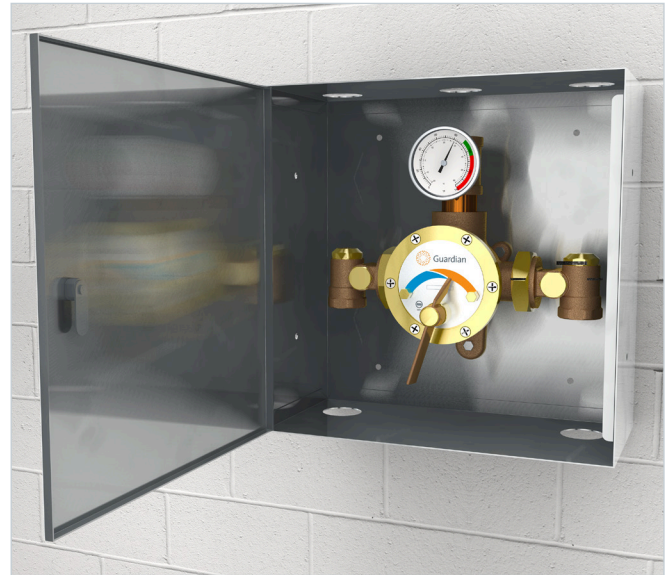

**IMPORTANT:** Pursuant to ANSI Z358.1-2014, the water delivered by emergency equipment should be "tepid". Tepid is defined as moderately warm or lukewarm, and is generally considered to be between 60°F (15°C) and 90°F (32°C). However, in certain circumstances, a chemical reaction may be accelerated or otherwise affected by the water temperature. Please consult with a medical advisor to determine the optimum delivered water temperature prior to specifying, installing or using a tempering valve.

*Tempering valves will not deliver the appropriate water temperature if the system has not been sized correctly. Please refer to the flow capacities and supply pressure requirements listed above when designing the tempered water system and selecting tempering valves.*

*Tempering valves, like all emergency eyewash and shower equipment, must be installed in accordance with the manufacturer's instructions and maintained on a regular basis. Under ANSI Z358.1-2014, all emergency equipment should be activated weekly and inspected at least annually. Tempering valves should be treated the same and, in addition, must be regularly cleaned and cycled.*

Distributed by:  
Safety Emporium  
PO Box 1003  
Blackwood, NJ 08012

Ph: (866) 326-5412 toll-free  
Fax: (866) 553-6154  
esupport@safetyemporium.com  
www.safetyemporium.com





### □ G3902LF Tempering Valve, 81 Gallon Capacity, Surface Mounted Stainless Steel Cabinet

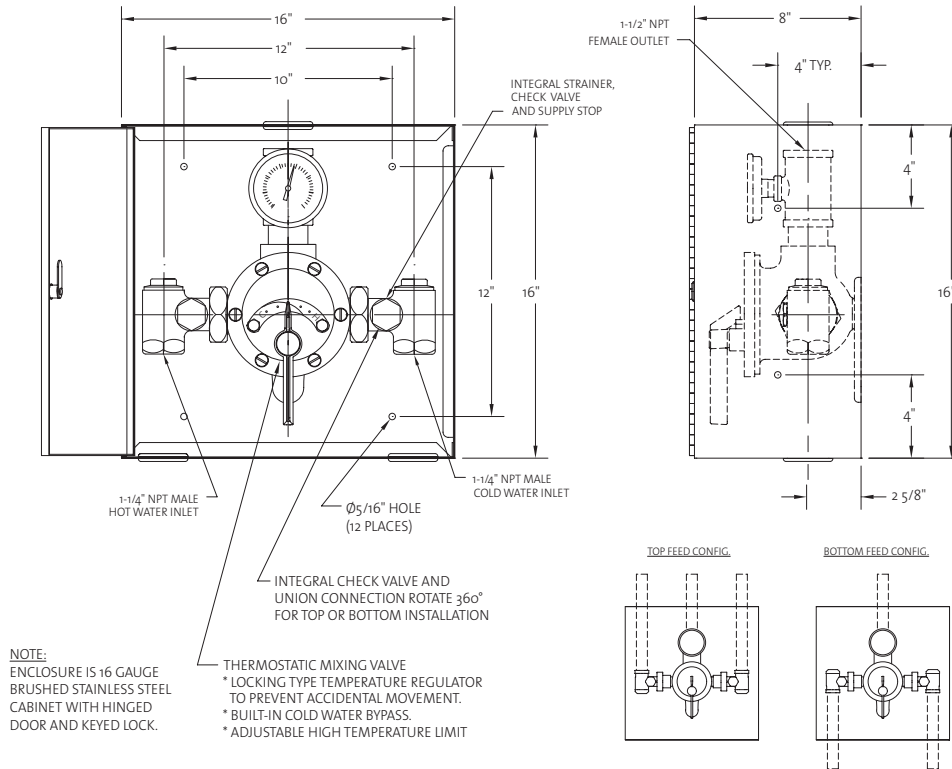

- As with all plumbing devices and emergency equipment, thoroughly flush supply lines prior to and after installation.
- Install mounting bracket on panel or wall. Thread tempering valve securely onto mounting bracket. Valve must be installed in location where it is readily accessible for inspection, cleaning and maintenance.
- Connect hot and cold water supply lines to valve. Connect outlet line to valve and then to inlet of emergency equipment.
- Activate the water flow and check the temperature of the water delivered from the tempering valve and emergency equipment. Note that the temperature control knob on the tempering valve has been factory preset to deliver 85°F (29°C) tepid water and the high temperature limit stop has been factory preset at 90°F (32°C). These temperatures are based upon an incoming hot water supply at 140°F (60°C). If the incoming hot water temperature is higher than 140°F (60°C), the valve will deliver water that is warmer than 90°F (32°C). ***In this case, the high temperature limit stop must be reset by the installer.***
- To reset the high temperature limit stop:
  - While the water is running, turn the adjusting knob counterclockwise to the maximum hot water position.
  - Remove the knob and retaining ring, loosen the set screw and remove the limit stop.
  - Replace the handle on the valve stem and rotate the valve stem until the desired outlet water temperature is reached. Confirm the outlet water temperature on the outlet thermometer.
  - Replace the limit stop on the valve stem, positioned so that the limit stop is against the web on the LEFT side of the valve cover (i.e. the valve stem cannot be turned any further counterclockwise).
  - Replace the retaining ring, tighten set screw and replace knob.

THIS SPACE FOR ARCHITECT/ENGINEER APPROVAL

Due to continuing product improvement, the information contained in this document is subject to change without notice. All dimensions are ± 1/4" (6mm). rev. 0215

