



- G5016** Drench Hose Unit, Wall Mounted
- G5016BP** Drench Hose Unit, Wall Mounted, with Backflow Preventer



Application: Drench hose unit for wall mounting. Ideal for rinsing any part of user's eye, face or body. *Note: Under ANSI Z358.1-2014, drench hose units supplement, but do not replace, other types of emergency equipment.*

Spray Head: Single FS-Plus™ spray head. Spray head has "flip top" dust cover, internal flow control and filter to remove impurities from the water flow.

Valve: Forged brass squeeze valve activated by stainless steel lever handle. Valve has replaceable stainless steel seat for exceptional durability. Valve closes when lever handle is released.

Hose: 12' reinforced nylon retractable coiled hose. 180 PSI maximum working pressure.

Mounting: Bracket with spring clips to hold unit on wall. Clips position spray head and handle to face forward at all times.

Backflow Preventer: In-line dual check backflow preventer installed on inlet of hose (G5016BP only). ASSE 1024 Listed. *Note: Check with code authority for compliance with local plumbing code.*

Supply: 3/8" NPT female inlet.

Sign: ANSI-compliant identification sign.

Quality Assurance: Unit is completely assembled and water tested prior to shipment.

Available Options

- LC** Locking clip for valve handle. Valve stays open until locking clip is released.
- VB** In-line vacuum breaker for installation between valve and spray head.
- G3600LF** Thermostatic mixing valve precisely blends hot and cold water to deliver warm (tepid) water as required by ANSI Z358.1-2014. Refer to "Tempering Valves" section for complete technical and product selection information.

Distributed by:
Safety Emporium
PO Box 1003
Blackwood, NJ 08012
Ph: (866) 326-5412 toll-free
Fax: (856) 553-6154
esupport@safetyemporium.com
www.safetyemporium.com



- **G5016** Drench Hose Unit, Wall Mounted
- **G5016BP** Drench Hose Unit, Wall Mounted, with Backflow Preventer

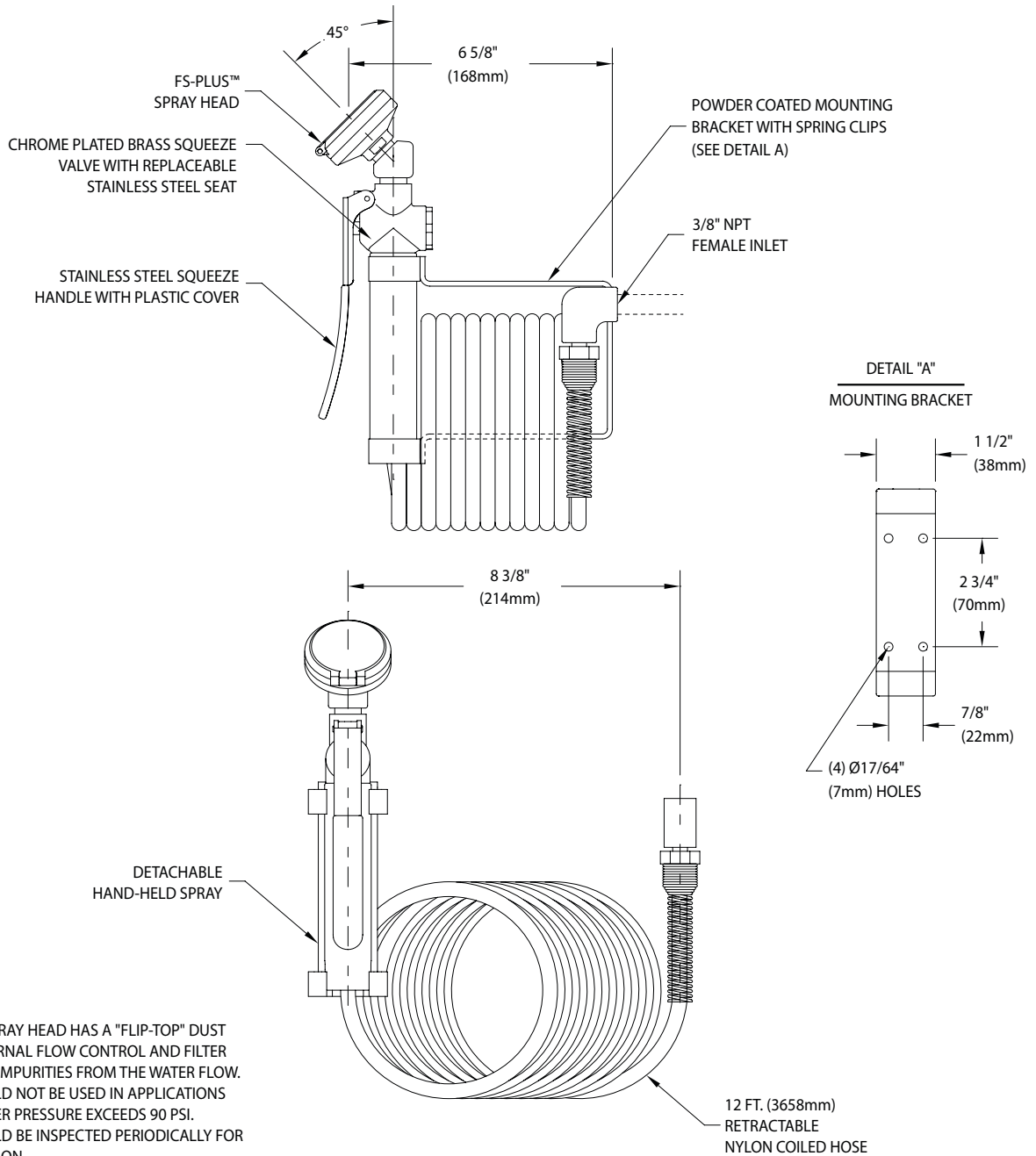

NOTES:

1. FS-PLUS™ SPRAY HEAD HAS A "FLIP-TOP" DUST COVER, INTERNAL FLOW CONTROL AND FILTER TO REMOVE IMPURITIES FROM THE WATER FLOW.
2. HOSE SHOULD NOT BE USED IN APPLICATIONS WHERE WATER PRESSURE EXCEEDS 90 PSI. HOSE SHOULD BE INSPECTED PERIODICALLY FOR DETERIORATION.

THIS SPACE FOR ARCHITECT/ENGINEER APPROVAL

Due to continuing product improvement, the information contained in this document is subject to change without notice. All dimensions are ± 1/4" (6mm). rev. 022219

Distributed by:
Safety Emporium
 PO Box 1003
 Blackwood, NJ 08012
 Ph: (866) 326-5412 toll-free
 Fax: (856) 553-6154
 esupport@safetyemporium.com
 www.safetyemporium.com

rev - 012218

Sign Included

