

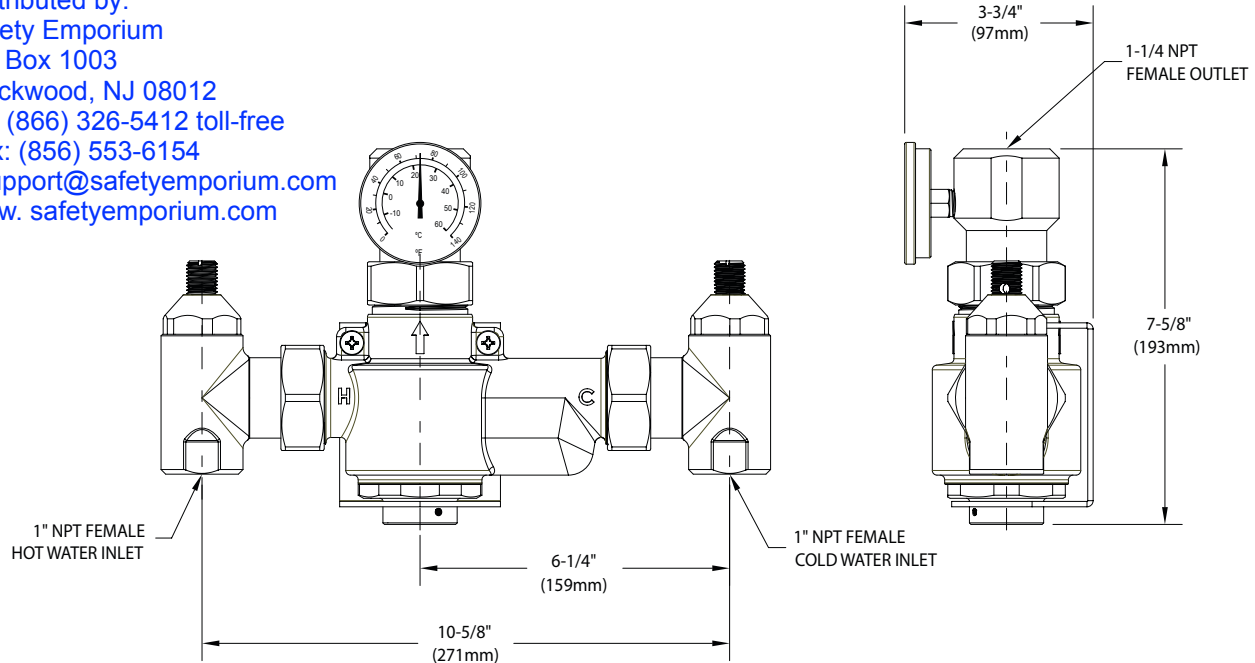

### Installation Instructions

Distributed by:  
 Safety Emporium  
 PO Box 1003  
 Blackwood, NJ 08012  
 Ph: (866) 326-5412 toll-free  
 Fax: (856) 553-6154  
 esupport@safetyemporium.com  
 www.safetyemporium.com



### Installation Instructions

1. The installation and field adjustment of the Thermostatic Mixing Valve are the responsibility of the installer and shall be carried out in accordance with the manufacturer's instructions.
2. Install Thermostatic Mixing Valve in a location where it can be easily cleaned, adjusted, or repaired.
3. Flush supply pipes before connecting the cold and hot check stops.
4. Inlets are marked on the Thermostatic Mixing Valve body, "H" for hot and "C" for cold.
5. Thread the hot and cold check stops to the hot and cold water supply pipes using thread sealant or PTFE tape.
6. Thread the outlet fitting to the outlet thread using thread sealant or PTFE tape.
7. Connect Thermostatic Mixing Valve body to the hot and cold water supplies using the supplied gaskets (See Detail A). Ensure that the mesh filters are installed in the Thermostatic Mixing Valve body. Tighten unions nuts to seal connection.
8. Connect Thermostatic Mixing Valve body outlet using the supplied gasket. Tighten union nut to seal the connection (See Detail B).
9. Flush outlet pipe and valve after the Thermostatic Mixing Valve has been connected.
10. Check stop valves are supplied with an internal shut-off device. Provision must be made to prevent these valves from being shut-off. Stem has  $\varnothing 13/64$ " (5.2mm) hole for attaching a locking mechanism.
11. If shut-off valves are installed on the inlet or outlet supplies provision must be made to prevent unauthorized shut-off.

### Specification Table

Inlet Hot Water Temperature Range	120-180°F (49-82°C)
Inlet Cold Water Temperature Range	40-70°F (4-21°C)
Maximum Supply Pressure	125 psi (862 kPa)
Outlet Temperature Setting	65-95°F (18-35°C)
Maximum Hot/Cold Differential Pressure	25%
Flow Rate at 30 psi (206.9 kPa) Pressure Drop	50 GPM (189 L/m)
Cold Water By-Pass Flow Rate at 30 psi (206.9 kPa) Pressure Drop	38 GPM (144 L/m)
Minimum Flow Rate	3.0 GPM (11.4 L/m)
Flow Rate with Cold Water Shut-Off	0.0 GPM (0.0 L/m)

Rev. 100620



### Operation, Testing and Maintenance

Distributed by:  
Safety Emporium  
PO Box 1003  
Blackwood, NJ 08012  
Ph: (866) 326-5412 toll-free  
Fax: (856) 553-6154  
esupport@safetyemporium.com  
www.safetyemporium.com

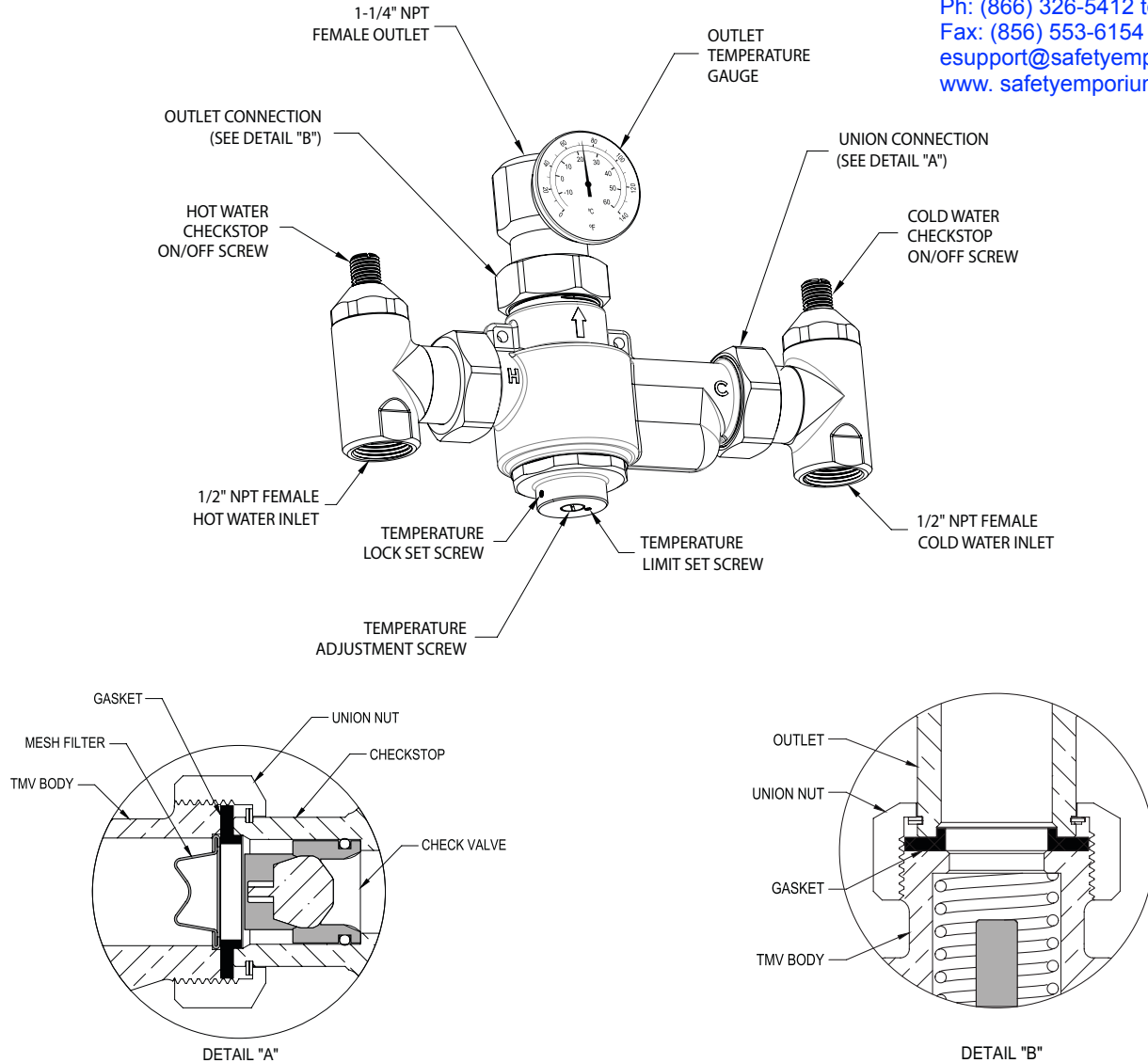

### Temperature Adjustment

1. The Thermostatic Mixing Valve has a factory preset temperature of 85°F (29.4°C). Consult medical and/or safety authorities for the correct temperature setting. Thermostatic Mixing Valve must be checked for final temperature and adjusted as necessary.
2. Adjustments to the outlet temperature must be done with the outlet water flowing, minimum flow rate of 3 GPM (11.4 L/m) is required.
3. With the outlet water flowing use a flat head screw driver turning the Temperature Adjustment Screw counter clockwise to increase the outlet water temperature and turning the Temperature Adjustment Screw clockwise to decrease the outlet water temperature.
4. High temperature limit stop has been factory set to 90°F (32°C).
5. No single emergency fixture supplied by this device has a minimum flow rate less than 3 GPM (11.4 L/m).

Rev. 100620

### Operation, Testing and Maintenance (continued)

#### Adjusting High Temperature Limit Stop

1. The High Temperature Limit Stop has been factory set to 90°F (32°C). If the desired outlet temperature can not be reached, the High Temperature Limit Stop can be adjusted to allow for a larger temperature range.
2. Adjustments to the Temperature Limit Stop must be done with the outlet water flowing, minimum flow rate of 3 GPM (11.4 L/m) is required.
3. Turn the Temperature Limit Set Screw counter clockwise to disengage the set screw from the Temperature Adjustment Screw.
4. Turn the Temperature Adjustment Screw counter clockwise to increase the outlet water temperature or clockwise to decrease the outlet water temperature until the correct high outlet water temperature is achieved.
5. Reengage the Temperature Limit Set Screw by turning the screw clockwise until it has engaged the Temperature Adjustment Screw.
6. Follow the Instructions for Temperature Adjustment to set your outlet temperature.

#### Testing

- Hot Water Shut-off Test: While the Thermostatic Mixing Valve is flowing a minimum of 3 GPM (11.4 L/m) at 85°F (29.4°C) shut-off the hot water supply to the Thermostatic Mixing Valve. Make sure that the cold water continues to flow. If the cold water continues to flow reopen the hot water supply.
- Cold Water Shut-off Test: While the Thermostatic Mixing Valve is flowing a minimum of 3 GPM (11.4 L/m) at 85°F (29.4°C) shut-off the cold water supply to the Thermostatic Mixing Valve. Make sure that the hot water stops flowing. If the hot water stops flowing reopen the cold water supply.
- Test Thermostatic Mixing Valve weekly for proper function and set temperature.

#### Maintenance

- Frequency of cleaning depends on the quality of local water condition and usage.
- Check and clean mesh filter as needed: Turn both the hot and cold water check stop valves clockwise shutting off the supply water to the Thermostatic Mixing Valve. Drain the remaining water from the outlet piping. Once the all the water is removed loosen the three union nuts and remove the mixing valve body from the piping. Save the three gaskets. With the Thermostatic Mixing Valve body removed both mesh filters can be accessed. Remove both the cold and hot mesh filters by pulling them out of the Thermostatic Mixing Valve body. Mesh filters should come out without the need of a tool. Inspect mesh filters, if needed clean or replace them. Install the mesh filters back into the Thermostatic Mixing Valve body according to (Detail A). Connect Thermostatic Mixing Valve body to the hot and cold water supplies using the saved gaskets. Tighten unions nuts to seal connection. Connect Thermostatic Mixing Valve body outlet using the saved gasket. Tighten union nut to seal the connection. Turn both the hot and cold water check stop valves counter clockwise turning on the supply water to the Thermostatic Mixing Valve. Check for any leaks.
- Test mixing valve weekly verifying outlet flow rate, outlet temperature, hot water shut-off, and cold water shut-off.

Distributed by:  
Safety Emporium  
PO Box 1003  
Blackwood, NJ 08012  
Ph: (866) 326-5412 toll-free  
Fax: (856) 553-6154  
[esupport@safetyemporium.com](mailto:esupport@safetyemporium.com)  
[www.safetyemporium.com](http://www.safetyemporium.com)

Rev. 100620