

○ **L4100-141FT** Laboratory Ball Valve Assembly, Wall Mounted Double, Brass Floating Escutcheon

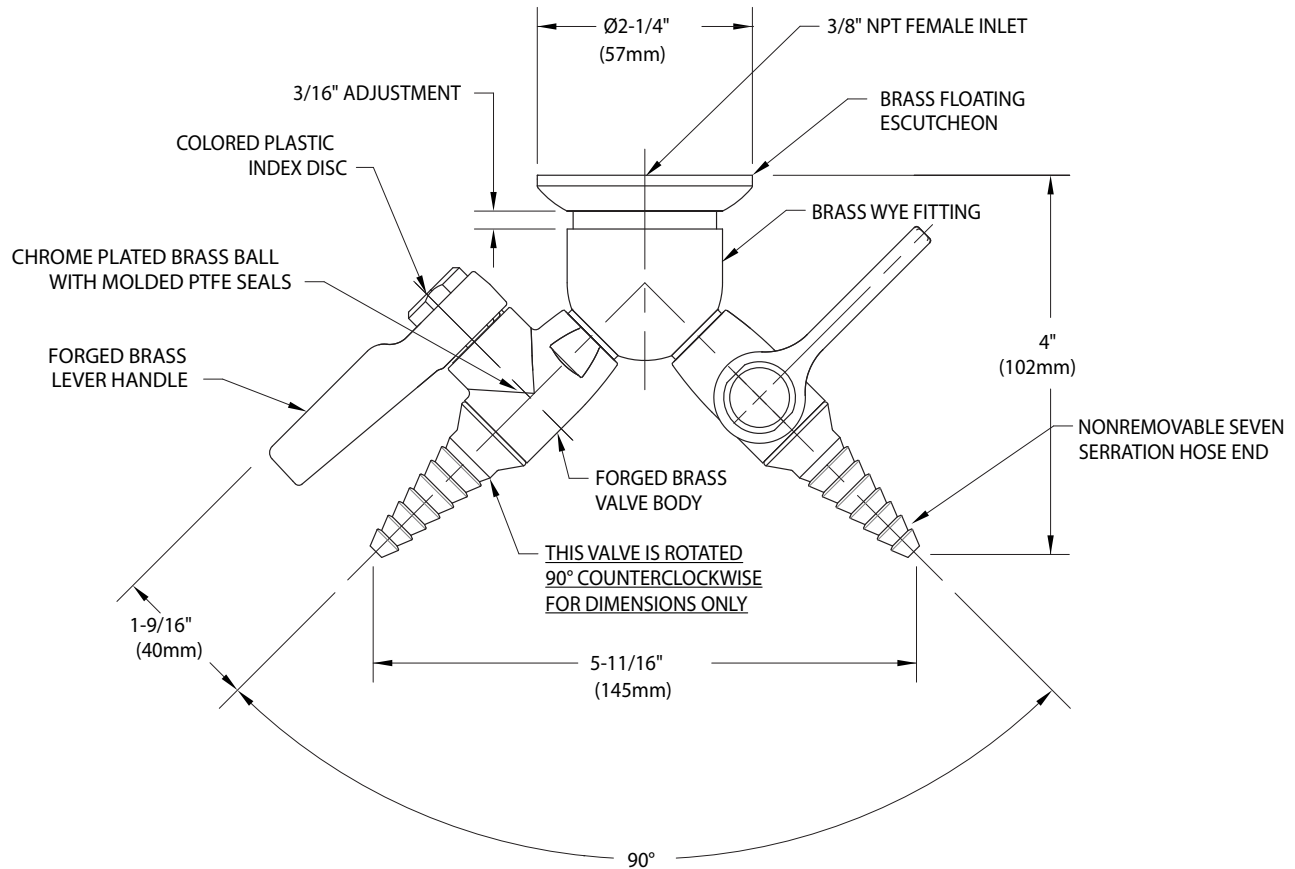

Distributed by:  
**Safety Emporium**  
 PO Box 1003  
 Blackwood, NJ 08012  
 Ph: (866) 326-5412 toll-free  
 Fax: (856) 553-6154  
[esupport@safetyemporium.com](mailto:esupport@safetyemporium.com)  
[www.safetyemporium.com](http://www.safetyemporium.com)



**NOTES:**

1. LABORATORY BALL VALVE ASSEMBLY IS CERTIFIED BY CSA INTERNATIONAL TO COMPLY WITH ANSI Z21.15 AND CGA 9.1.
2. FIXTURE HAS FEMALE INLET FOR CONNECTION TO SUPPLY. FLOATING ESCUTCHEON IS THREADED TO WALL TO CONCEAL ANY GAP BETWEEN VALVE AND WALL.
3. FIXTURE IS FULLY ASSEMBLED AND FACTORY TESTED AT 125 PSI AIR PRESSURE. MAXIMUM WORKING PRESSURE IS 75 PSI.
4. SPECIFY IF CLEANING FOR OXYGEN AND HIGH PURITY GASES IS REQUIRED
5. VALVE HAS A POLISHED CHROME PLATED FINISH.

Measurements may vary  $\pm 1/4$ ".