

○ L4100-141WSA Laboratory Ball Valve Assembly, Panel Mounted Double

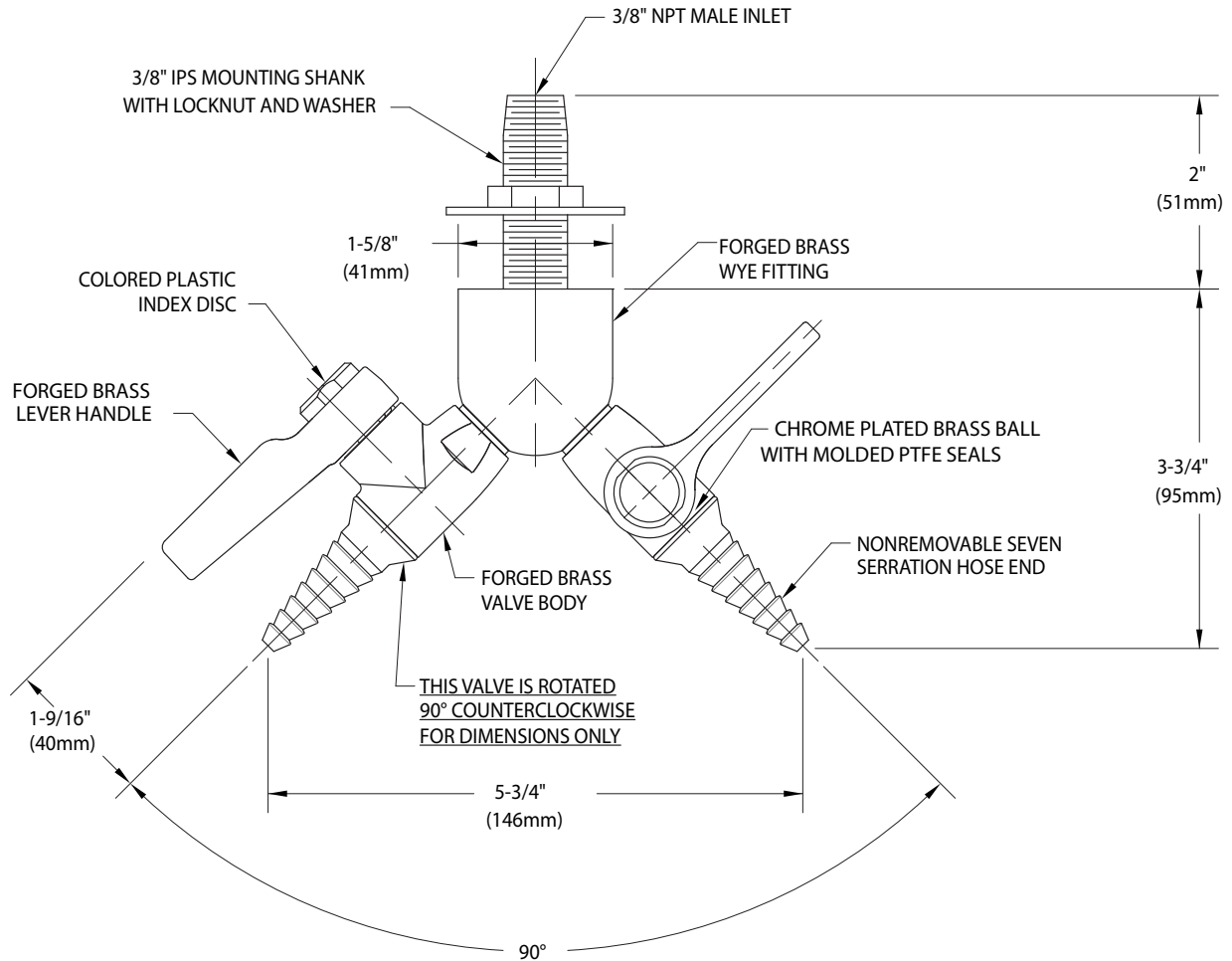

Distributed by:
 Safety Emporium
 PO Box 1003
 Blackwood, NJ 08012
 Ph: (866) 326-5412 toll-free
 Fax: (856) 553-6154
esupport@safetyemporium.com
www.safetyemporium.com

NOTES:



1. LABORATORY BALL VALVE ASSEMBLY IS CERTIFIED BY CSA INTERNATIONAL TO COMPLY WITH ANSI Z21.15 AND CGA 9.1.
2. FIXTURE IS FULLY ASSEMBLED AND FACTORY TESTED AT 125 PSI AIR PRESSURE. MAXIMUM WORKING PRESSURE IS 75 PSI.
3. SPECIFY IF CLEANING FOR OXYGEN AND HIGH PURITY GASES IS REQUIRED
4. FIXTURE HAS A POLISHED CHROME PLATED FINISH.

Measurements may vary $\pm 1/4$ ".