

**L4870F-225WSA** Fine Control Needle Valve Assembly, Panel Mounted

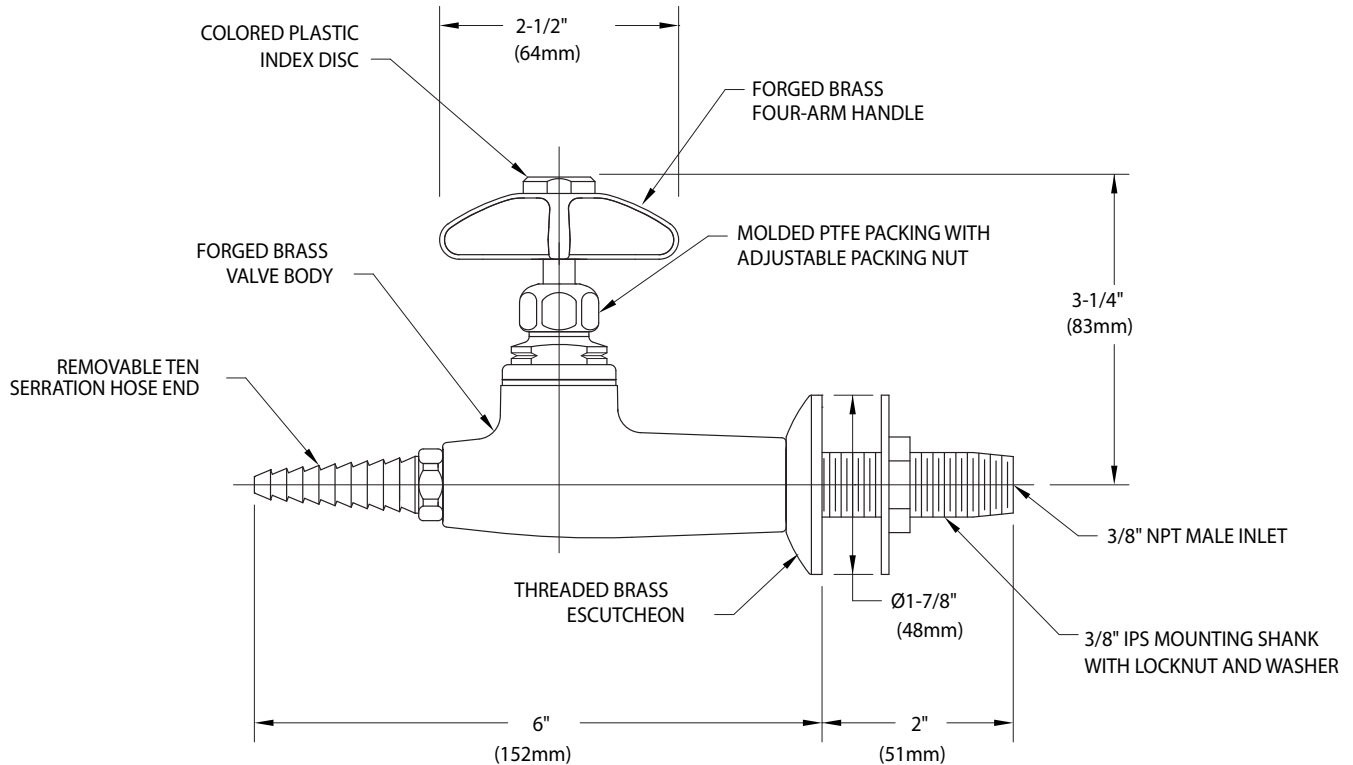

Distributed by:  
**Safety Emporium**  
 PO Box 1003  
 Blackwood, NJ 08012  
 Ph: (866) 326-5412 toll-free  
 Fax: (856) 553-6154  
[esupport@safetyemporium.com](mailto:esupport@safetyemporium.com)  
[www.safetyemporium.com](http://www.safetyemporium.com)

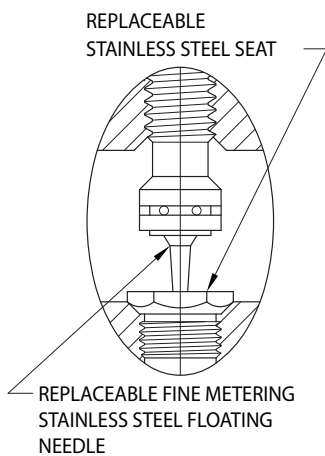

**NOTES:**

1. FURNISHED WITH THREADED ESCUTCHEON, MOUNTING SHANK, LOCKNUT AND WASHER FOR SECURING TO PANEL.
2. FIXTURE IS CLEANED, DEGREASED AND PACKED FOR HIGH PURITY GAS SERVICE.
3. FIXTURE IS FULLY ASSEMBLED AND TESTED AT 375 PSI NITROGEN PRESSURE. MAXIMUM WORKING PRESSURE IS 250 PSI.
4. FIXTURE HAS A POLISHED CHROME PLATED FINISH.

Measurements may vary  $\pm 1/4$ ".