

### ○ L4880F-225WSA Needle Valve Assembly, Panel Mounted

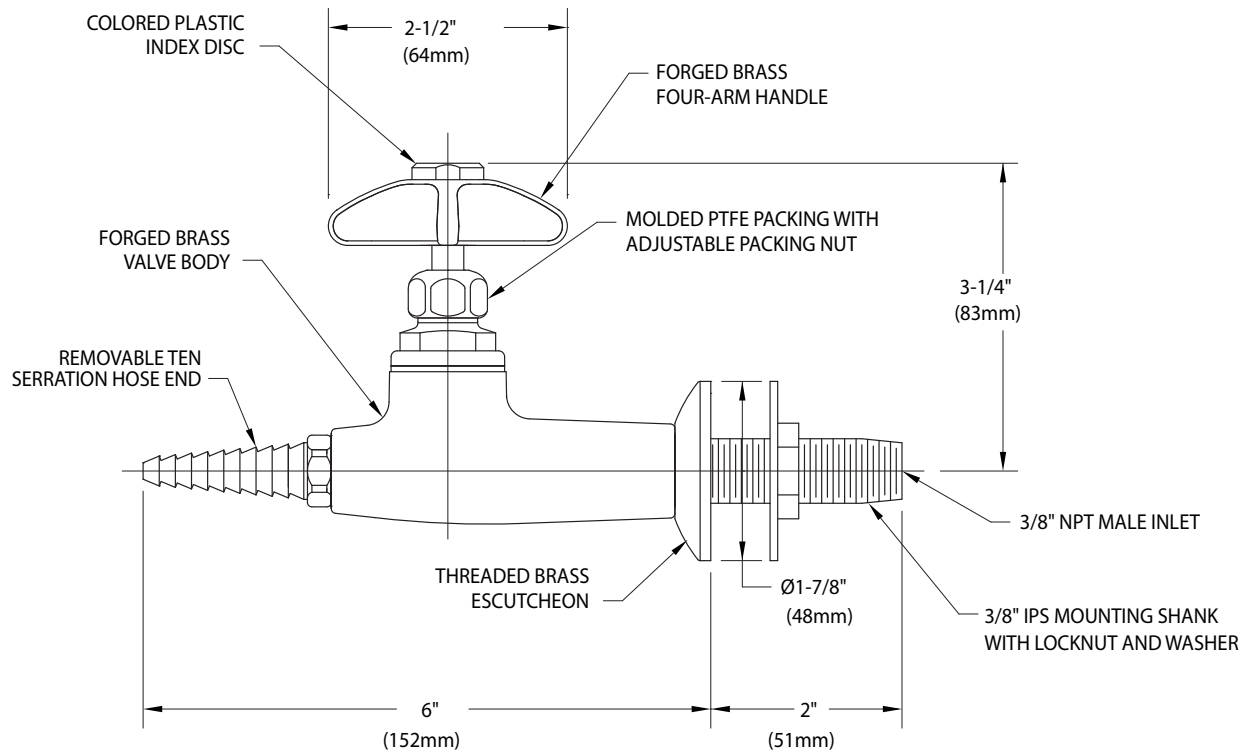

Distributed by:  
**Safety Emporium**  
 PO Box 1003  
 Blackwood, NJ 08012  
 Ph: (866) 326-5412 toll-free  
 Fax: (856) 553-6154  
[esupport@safetyemporium.com](mailto:esupport@safetyemporium.com)  
[www.safetyemporium.com](http://www.safetyemporium.com)

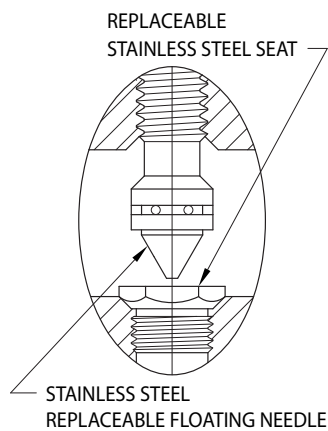

#### NOTES:

1. FURNISHED WITH THREADED ESCUTCHEON, MOUNTING SHANK, LOCKNUT AND WASHER FOR SECURING TO PANEL.
2. VALVE IS CERTIFIED BY CSA INTERNATIONAL TO COMPLY WITH ANSI Z21.15 AND CGA 9.1.
3. FIXTURE IS FULLY ASSEMBLED AND FACTORY TESTED AT 250 PSI NITROGEN PRESSURE. MAXIMUM WORKING PRESSURE IS 150 PSI.
4. SPECIFY IF CLEANING FOR OXYGEN AND HIGH PURITY GASES IS REQUIRED.
5. FIXTURE HAS A POLISHED CHROME PLATED FINISH.



Measurements may vary  $\pm 1/4$ ".