

○ **L5100F-225WSA** Laboratory Water Valve Assembly, Panel Mounted

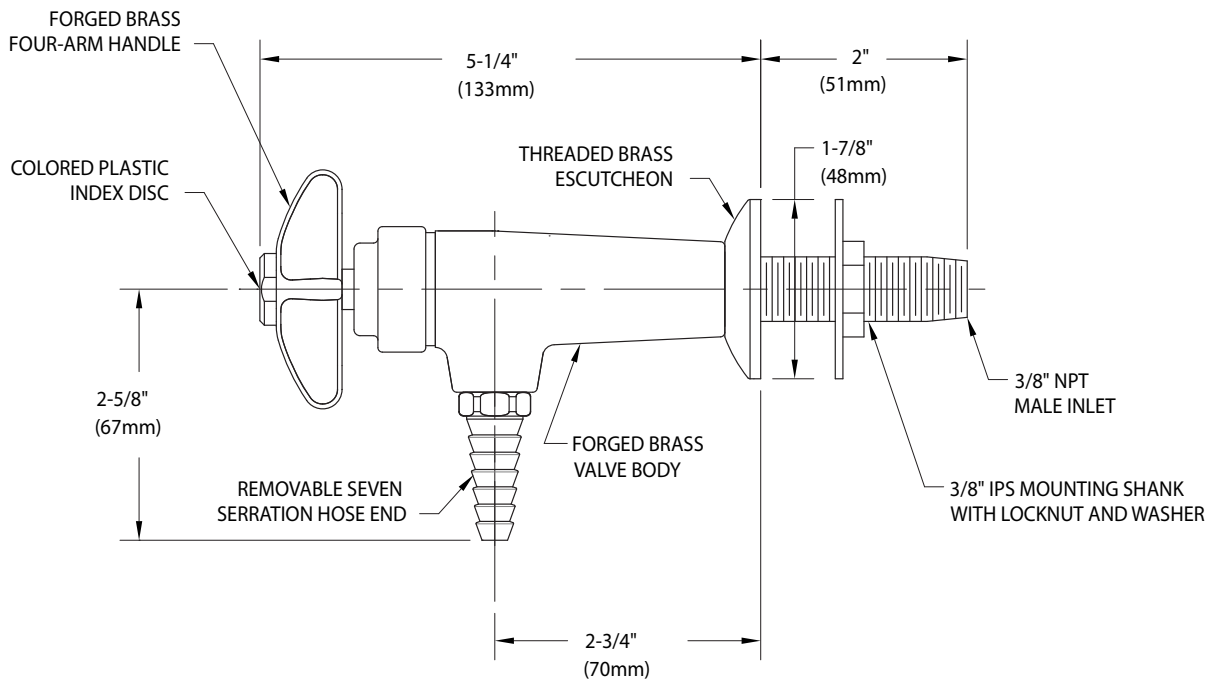

Distributed by:
 Safety Emporium
 PO Box 1003
 Blackwood, NJ 08012
 Ph: (866) 326-5412 toll-free
 Fax: (856) 553-6154
esupport@safetyemporium.com
www.safetyemporium.com

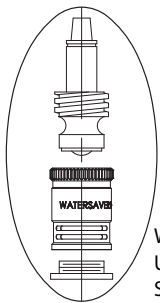

WATER SAVER RENEWABLE
 UNIT WITH REPLACEABLE
 STAINLESS STEEL SEAT

NOTES:



1. FIXTURE IS CERTIFIED BY CSA INTERNATIONAL TO COMPLY WITH ASME A112.18.1M AND CSA B125.1.
2. FURNISHED WITH THREADED ESCUTCHEON, MOUNTING SHANK, LOCKNUT AND WASHER FOR SECURING FIXTURE TO PANEL.
3. FIXTURE IS FULLY ASSEMBLED AND FACTORY TESTED PRIOR TO SHIPMENT.
4. FIXTURE HAS A POLISHED CHROME PLATED FINISH.

Measurements may vary $\pm 1/4$ ".