

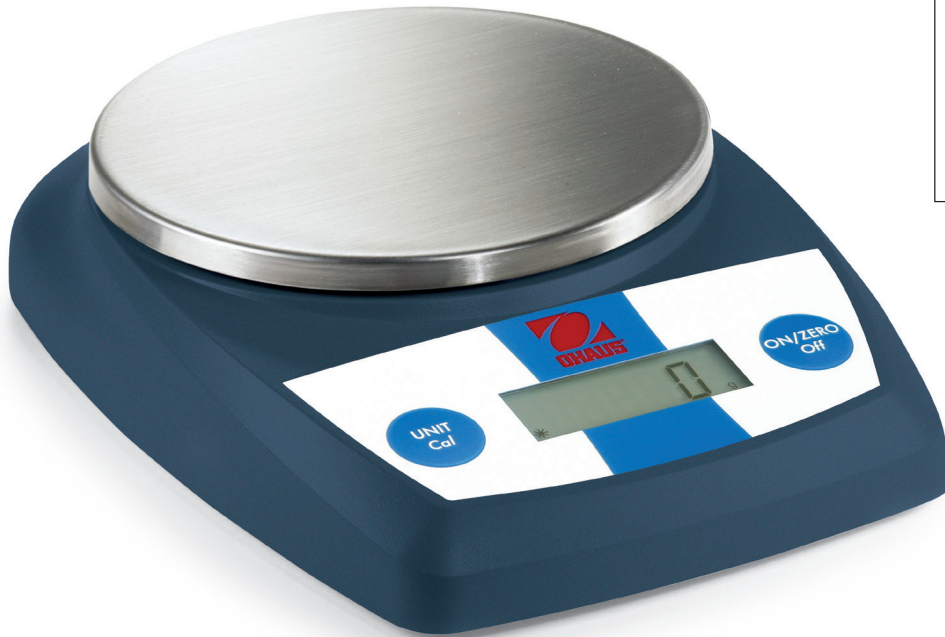

# OHAUS CL5000F

Portable Culinary Scale



CL5000F Scale shown with included carry case

## ***Designed for use in culinary portioning, baking and pastry applications!***

The OHAUS CL5000F Scale combines precision measurement, easy-to-clean design and portability in one affordable package. Each scale comes with a removable, stainless steel weighing pan and a padded semi-soft carrying case.

### ***Standard Features Include:***

- Sealed front panel for added resistance to spills
- Removable stainless steel pan
- High contrast LCD for fast weight display
- Shipping lock for added protection during transport
- Battery power with auto-shut off feature – batteries included
- AC power optional
- Calibration software included – calibration mass optional
- Padded, semi-soft carrying case included

Distributed by:  
Safety Emporium  
PO Box 1003  
Blackwood, NJ 08012  
Ph: (866) 326-5412 toll-free  
Fax: (856) 553-6154  
[esupport@safetyemporium.com](mailto:esupport@safetyemporium.com)  
[www.safetyemporium.com](http://www.safetyemporium.com)

# CL5000F Portable Culinary Scale

Model	CL5000F
Capacity x Readability	5,000g x 1g 11lb:0.4oz x 0.1oz 176.0 x 0.1oz
Repeatability (std. deviation)	1 g
Linearity	+/- 1g
Weighing Units	g, oz, combined lb:oz
Display	LCD display, 0.5 in / 1.2 cm high
Display Indicators	Stability, Low Battery, Overload, Underload
Keyboard	2 Raised Tactile Mechanical switches: Unit/Cal and On/Zero/Off
Tare Range	To full capacity by subtraction
Stabilization Time	2 seconds
Optimum Operating Temperature	65°F to 77°F / 18° to 25°C
Power	3 AA batteries (included) AC Adapter optional accessory
Battery Life	40 hours
Calibration	Digital calibration from keypad with optional external calibration mass
Shipping Protection	Integrated shipping lock, included carrying case
Pan Size	4.75 in diameter / 12 cm
Scale Dimensions	5.5 x 1.6 x 7.9 in / 14 x 4 x 20 cm
Net Weight	0.875 lb / 0.4 kg
Shipping Dimensions	11.25 x 4.25 x 8.75 in / 29 x 11 x 22.25 cm
Shipping Weight	2.75 lb / 1.25 kg

## Standard Features

High contrast LCD, auto shut-off, indicators for stability, overload, underload, and low battery. CL5000F model includes stainless steel pan cover and padded, semi-soft carrying case as standard. AC adapter pack and calibration mass optional accessories.

## Accessories

Carrying Case..... 80010624

Steel Pan Cover..... 80010623

## Industry Leading Quality and Support

All OHAUS CL5000F Culinary Scales are manufactured under an ISO 9001:2008 Registered Quality Management System. Our rugged construction and stringent quality control have been hallmarks of all OHAUS products for over a century.

## Outline Dimensions

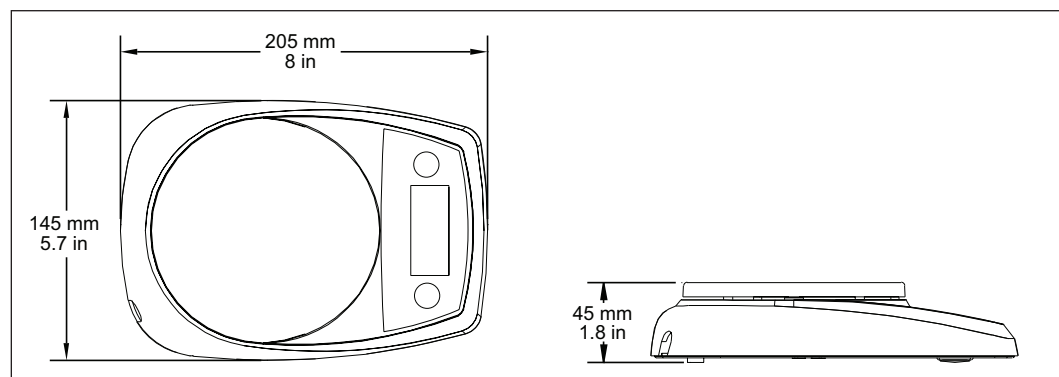

Distributed by:  
**Safety Emporium**  
 PO Box 1003  
 Blackwood, NJ 08012  
 Ph: (866) 326-5412 toll-free  
 Fax: (856) 553-6154  
[esupport@safetyemporium.com](mailto:esupport@safetyemporium.com)  
[www.safetyemporium.com](http://www.safetyemporium.com)

### OHAUS CORPORATION

\*7 Campus Drive  
 Suite 310  
 Parsippany, NJ 07054 USA

Tel: 800.672.7722  
 973.377.9000  
 Fax: 973.944.7177

[www.ohaus.com](http://www.ohaus.com)

With offices throughout  
 Europe, Asia, and  
 Latin America

\*ISO 9001:2008  
 Registered Quality  
 Management System

